



fluidity.
nonstop

IT'S ABOUT KEEPING YOUR PROCESSES RUNNING

**PRODUCT
CATALOGUE**

 **AXFLOW**

ABOUT AXFLOW

Since its founding in 1989, AxFlow has represented the world's leading manufacturers of industrial and laboratory pumps, agitators and other process equipment.

AxFlow group in the world

- Over 700 experts in the field of fluid mechanics and process technology
- Representation in 29 countries in Europe, South Africa, Australia and New Zealand
- Central distribution warehouse in the Netherlands with delivery of critical parts within 48 hours
- AxFlow Systems - design and construction of complete solutions for pumping, vacuum and other process systems
- Strong financial background and unique corporate culture of owner Axel Johnson, founded in 1873



CENTRAL DISTRIBUTION WAREHOUSE, LELYSTAD, NETHERLANDS

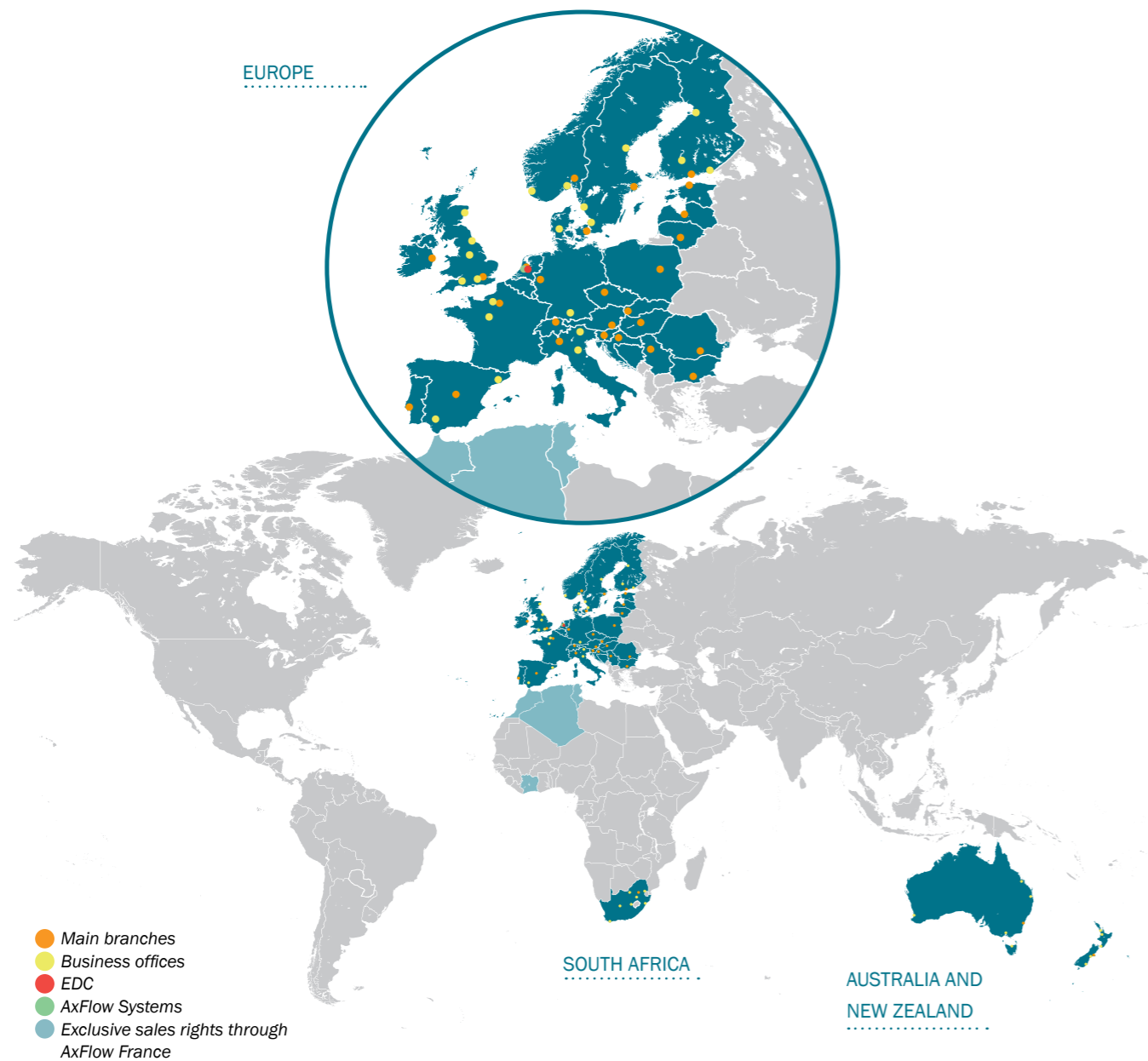

AxFlow in the Czech Republic and Slovakia offers:

- wide portfolio of high-end process equipment (positive displacement and centrifugal pumps, vacuum pumps, agitators, mixers, heat exchangers, homogenizers, separators, valves, filters)
- original spare parts with fast delivery
- regular and emergency service
- fast-growing engineering department
- design, delivery and commissioning of complete solutions
- detailed documentation
- expert assistance and consulting
- detailed product information on the website www.axflow.cz





AxFlow is not just a supplier of individual pumps, vacuum pumps and other process components.

We also build complex pumping, vacuum and mixing systems tailored to customer and application requirements.

It doesn't matter if you need to dispense chemicals, extract steam or deal with a CIP process in the pharmaceutical industry. We are delivering more and more complete systems to our customers and we enjoy it.

Contact us and we'll create one for you too!

AXFLOW SYSTEMS – OUR APPROACH

-  Thorough consultation with the customer
-  System design and complete 2D and 3D documentation
-  Professionally executed assembly
-  System testing and detailed documentation
-  Delivery, installation and commissioning at the customer's site
-  After-sales service and maintenance



AxFlow brings you the complete product portfolio from SPX Flow

SPX Flow is a global manufacturer of a wide range of specialized equipment for the process industry such as **positive displacement and centrifugal pumps, valves, agitators, filters, hydraulic components, homogenizers, separators and heat exchangers**. These products have gained a reputation in many industries, mainly in the food and energy segments. SPX Flow operates in more than 35 countries and distributes its products in more than 150 countries worldwide.

Our product portfolio includes all the brands below.

- > APV®
- > Waukesha
Cherry-Burrell®
- > Lightnin®
- > Bran+Luebbe®
- > Plenty®
- > Seital® Separation



Homogenizers



APV is a leading supplier of high-pressure homogenizers that can develop pressure up to 2.000 bar when processing emulsions and dispersions. Simply put, homogenizers consist of a positive displacement pump that pushes the medium through a homogenizing valve.

Typical applications of APV homogenizers:

- dairy products
- ice cream
- ketchup and tomato sauce
- cream sauces
- biotechnology
- paints and coatings
- wax and silicone emulsions

Homogenization principle:

The unhomogenized product enters the valve at high pressure and low velocity. As the product enters the gap between the valve and the seat, there is a rapid increase in velocity with a corresponding decrease in pressure. The intense energy release causes turbulence and local pressure differences, which will tear apart the particles.

Homogenization benefits:

- extended shelf stability, improved smoothness
- reduced ingredient cost
- improved water binding
- improved chemical reactions due to larger surface area of small particles compared to fewer large particles

Homogenization valve is the heart of the whole process. APV provides different types of valves to achieve the best homogenization performance, depending on the media being processed.

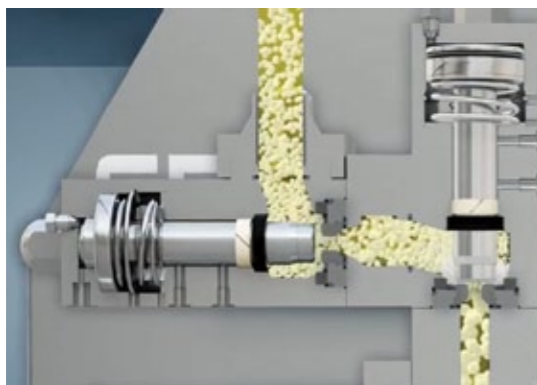

DOUBLE-STAGE HOMOGENIZATION

XFD valve

- standard valve for all types of products, typically used as a single-stage valve or as the first stage in a double-stage configuration
- maximum pressure up to 400 bar
- material: stellite, ceramic and tungsten carbide

LW valve

- double-stage homogenizing valve
- no need for a double-stage machine
- pressure up to 250 bar and for fluids with a maximum fat content up to 13 %
- material: stellite

SEO valve

- mostly used in the pharmaceutical industry
- flat valve for abrasive products
- for pressures over 600 bar
- material: stellite, ceramic and tungsten carbide



XFD VALVE

LW VALVE

SEO VALVE

Micro Gap

- the most efficient valve on the market (25% bonus), lower pressure required for the same homogenizing effect compared to common valves
- multiple valves assembled together
- for high volume flow rates (4.500 l/h per valve)



MICRO GAP VALVE



Homogenizers



Design of homogenizers

APV homogenizers combine the best features of the established homogenizer manufacturers Rannie and Gaulin. For each specific process and application we offer a specific homogenizing valve solution.



RANNIE - 3-PIECE CYLINDER BLOCK WITH HYDRAULIC ACTUATION

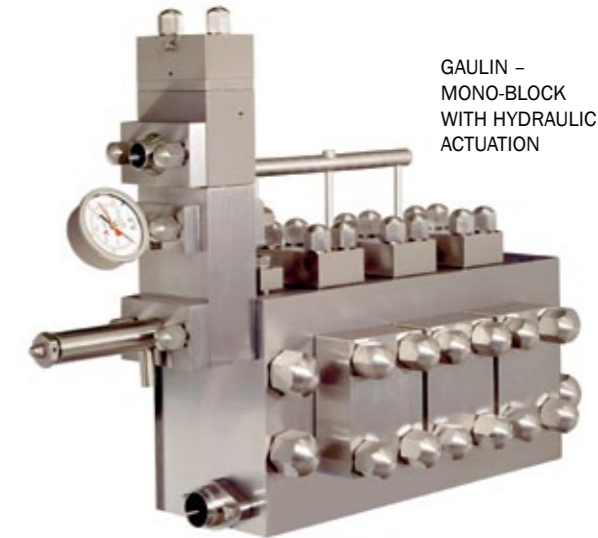

GAULIN - MONO-BLOCK WITH HYDRAULIC ACTUATION

Rannie series maximum parameters

Flow rate:	80-45.000	l/h
Pressure:	150-1.500	bar

Gaulin series maximum parameters

Flow rate:	180-50.000	l/h
Pressure:	100-600	bar

APV laboratory homogenizers

A simple solution for high-pressure homogenization of samples and small product quantities, allowing easy performance testing for subsequent large-scale production.



APV LABORATORY HOMOGENIZER

Other benefits:

- compact tabletop design
- aseptic plunger design
- adjustable pressure up to 1.000/2.000 bar
- flow rate 11-22 l/h
- easy commissioning without the need for additional devices
- integrated reservoir for the inlet product
- optional suction pressurisation for viscous media
- particle size up to 200 microns
- possibility to borrow or test samples directly in the AUV laboratory
- ATEX option available

Maximum parameters

Flow rate:	11-22	l/h
Pressure:	1.000-2.000	bar



Homogenizers

APV Pilot 4T

Compact and economical homogenizer with modern controls for most food applications (including CIP/SIP) with low flow rate and pressure up to 600 bar.



APV PILOT 4T

Other benefits:

- continuous homogenization 20 - 600 l/h
- homogenizing pressure up to 210/400/600 bar
- simple interface for manual or automated control
- aseptic design
- modern IE5 drive
- manual or automatic control

	13.38	18.38	24.38	
Flow rate:	20-135	50-300	90-600	l/h
Pressure:	600	400	210	bar

APV Rannie/Gaulin process homogenizers

Modular solution of the legendary Rannie and Gaulin homogenizers for continuous production at small and large outputs. Our process homogenizers come with correct filling system, complete controls and commissioning.



APV RANNIE GAULIN 5

Rannie Gaulin 5 series maximum parameters

Flow rate:	900	l/h
Pressure:	1.000	bar



RANNIE 275Q

Rannie Gaulin 185Q/275Q series maximum parameters

Flow rate:	50.000	l/h
Pressure:	650	bar



Circumferential piston pumps

Waukesha Universal 1/Universal 2

Characteristics: pulseless run, gentle pumping, dry running, high-efficiency pumping without dead spaces

Other benefits:

- materials: SS 316L wetted parts, Alloy 88 rotors
- robust design for demanding applications and smooth run
- mechanical and O-ring seals
- connection size: 1" - 8"
- CIP/SIP cleaning
- full stainless steel pump body option

Food and pharmaceutical industry applications:

Universal series are developed for applications in the food and pharmaceutical industry, where gentle and maximally hygienic pumping is required.

Application in other industries:

These series are also suitable for a wide range of applications in most other industrial applications thanks to the robust construction, option of pressurized seals with API 53A/B certification, ATEX certification and Armoloy coating.

Accessories:

Jacketed cover, valve lid, integrated safety valve, a wide range of rotor options, extended ports, rectangular flange inlet, Armoloy coating for maximum abrasion resistance (hardness:78 HRC).

Universal 1 series maximum parameters

Flow rate:	102	m ³ /h
Pressure:	14	bar
Product temperature:	149	°C

Universal 2 series maximum parameters

Flow rate:	150	m ³ /h
Pressure:	34	bar
Product temperature:	149	°C

Waukesha Cherry-Burrell



UNIVERSAL 1 - BASIC VERSION



UNIVERSAL 1 - JACKETED MONO-BLOCK VERSION



UNIVERSAL 2 - VERTICAL VERSION WITH RECTANGULAR FLANGE INLET



UNIVERSAL 2 - ASSEMBLY WITH DRIVE ON A PLATE



Circumferential piston pumps

Waukesha Universal 3

The latest, enhanced addition to Waukesha circumferential piston pump family with simplified servicing.

Benefits:

- materials: SS 316L wetted parts, Alloy 88 non-galling rotors
- robust design for heavy-duty applications and trouble-free operation
- connection size: 1" - 8"
- CIP/SIP cleaning
- standard all-stainless steel pump body
- reduced service and maintenance costs due to the possibility of replacing the seal without dismantling the pump head
- multiple seal options: O-ring, single or double mechanical seal
- unrivalled solution for chocolate processing thanks to the O-ring seal, EHEDG and 3A certification

Universal 3 series maximum parameters

Flow rate:	150	m ³ /h
Pressure:	34	bar
Product temperature:	149	°C

Waukesha Cherry-Burrell



UNIVERSAL 3

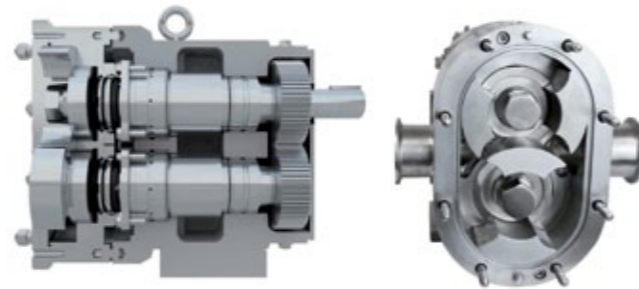

UNIVERSAL 3 - ROTOR DETAIL

APV DW

Sanitary rotary piston/lobe pump appropriate for high product temperature processes.

Benefits:

- SS 316L stainless steel wetted parts
- rotors made of special non-galling stainless steel, reducing damage on contact
- multiple seal options: single or double mechanical seal, packing gland seals, triple lip seals
- elastomers: PTFE, EPDM or FPM
- other options: rectangular suction inlet, jacketed body cover

DW series maximum parameters

Flow rate:	93	m ³ /h
Pressure:	30	bar
Product temperature:	180	°C



APV DW



Rotary lobe pumps

Waukesha MDL/TLP

New generation of affordable basic rotary lobe pumps for hygienic and industrial applications.

Benefits:

- materials: SS316L for wetted parts
- hygienic construction
- economical design
- CIP cleaning
- medium viscosity up to 20.000 cP
- full drainability in vertical position
- single or double mechanical seals with flushing
- Viton or EPDM elastomers
- connection: DIN 11851, SMS

Waukesha Cherry-Burrell



WAUKESHA MDL/TLP

MDL/TLP series maximum parameters

Flow rate:	124	m ³ /h
Pressure:	10	bar
Product temperature:	90	°C



Screw pumps

Waukesha Twin Screw

Characteristics: Pumps products containing particles without the risk of degradation. Possibility of pumping aerated products. Quick access to the seal for easy maintenance. High pump performance even at smaller sizes.

Benefits:

- suitable as product and CIP pump
- full CIP and SIP cleanability
- ability to pump mixtures of liquid and air
- gentle pumping
- medium viscosity up to 1.000.000 cP
- fully pulseless run
- single/double cartridge mechanical seal (SiC, TC) with quick replacement
- hygienic and flange connections
- FKM, EPDM elastomers
- pump and screw material SS316L
- port size 1.5" to 6"

Waukesha Cherry-Burrell



WAUKESHA TWIN SCREW

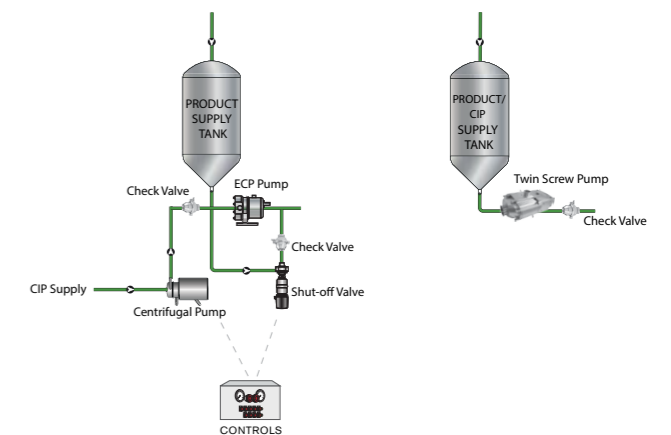

SIMPLIFYING CIP INSTALLATION WITH SCREW PUMP

Twin Screw series maximum parameters

Flow rate:	200	m ³ /h
Pressure:	25	bar
Product temperature:	130	°C



Centrifugal pumps



APV sanitary centrifugal pumps

W+ series

Characteristics: APV W+ series is a broad modular family of premium sanitary pumps designed to save costs during both operation and service.

Benefits:

- sanitary and robust design
- massive back-plate
- highly efficient and quiet run with minimum vibration
- the spring of the static part of the seal isn't wetted by the product and the single mechanical seal can be easily converted to a double seal
- designed for CIP/SIP
- materials: SS 316L wetted parts, SS304 for other parts
- optional polishing to Ra 0,8/0,5
- elastomers: EPDM, FPM, PTFE with FPM core
- seal materials: C/SiC or SiC/SiC

W+ series maximum parameters

Flow rate:	750	m ³ /h
Max. head:	150	m
Product temperature:	95	°C



APV W+ BASIC VERSION



APV DETAIL OF THE MECHANICAL SEAL

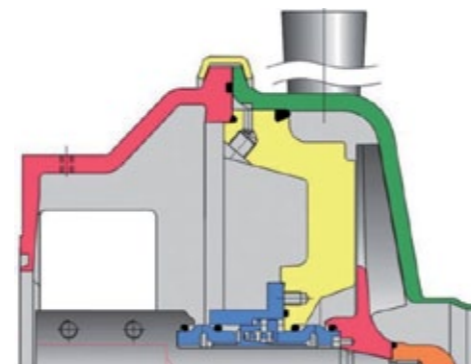

APV WA+ DETAIL OF THE ASEPTIC SEAL



APV WS+ SELF-PRIMING VERSION

Wa+ aseptic version

- for perfectly sterile production in the pharmaceutical industry
- special aseptic fittings for sterile rinsing
- double seals

Ws+ self-priming version

- simulates the principle of a liquid ring vacuum pump for better suction capabilities
- recirculation pipe to ensure the fluid presence
- designed for CIP/SIP
- typical applications: supply tank draining, pumping of aerated fluids
- ideal for CIP return line



Centrifugal pumps



Wi+ inducer series

Inducer is a hydraulic element in the suction port of the pump that improves NPSH. It can thus be an alternative to redesigning pipelines and equipment if the pump is on the verge of cavitation.

- lower NPSHr
- easy rebuild from the basic version
- designed for CIP/SIP



APV WI+ WITH INDUCER

Whp+ high-pressure series

Pumps are designed to withstand system pressure up to 60 bar, making them ideal for reverse osmosis systems. Heavy-duty construction increases stability and dampens vibrations in the process.

- designed for CIP/SIP
- heads of 70 m
- 4 pump sizes
- jacketed cover - optional
- wide range of connections - clamps, sanitary and industrial flanges



APV WHP+ HIGH-PRESSURE VERSION

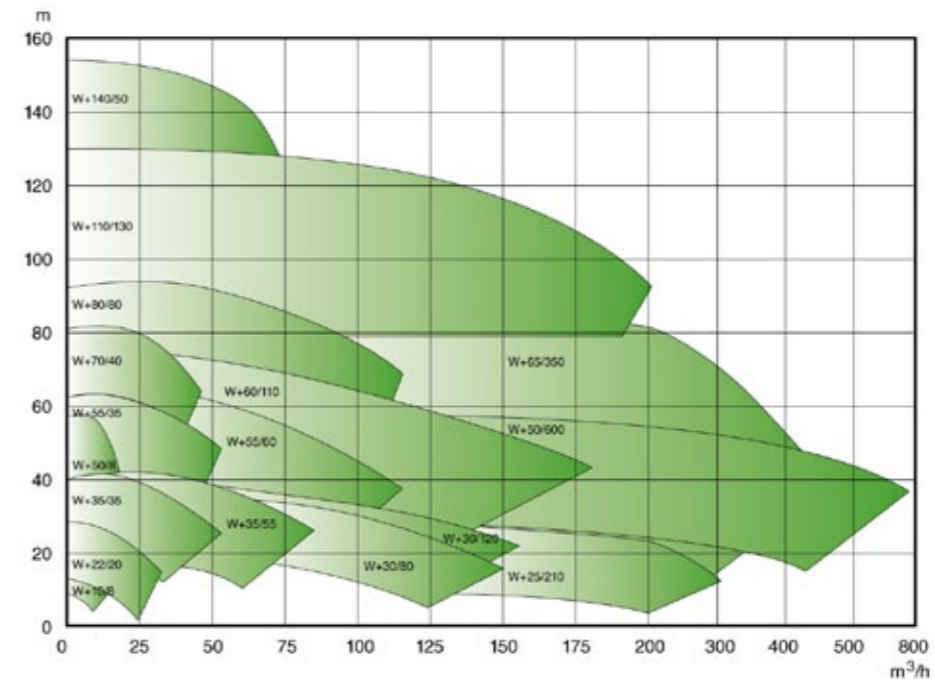

APV W+ SERIES PERFORMANCE CURVES



Metering pumps

Diaphragm and plunger metering pumps

Characteristics: high precision dosing for high pressures, dry running, meets and exceeds API 675 requirements: accuracy > 0.5%, linearity > 3%, repeatability > 1.5%

Other benefits:

- materials: SS316, SS316L, SS316Ti, SS304L stainless steel, PP, PVC, PVDF, special on request
- unique double-acting pump head
- diaphragm sealless pump with high efficiency
- hydraulic diaphragm drive - high durability
- parallel dosing of multiple products at once with individual regulation
- mechanic, electric or pneumatic stroke length adjustment
- building customized customer systems

Accessories:

safety, bypass, vent valves, dampers, calibration cylinders, suction filters



PROCAM SMART – BASIC LINE OF DIAPHRAGM/PLUNGER METERING PUMPS WITH MECHANICALLY ADJUSTED DIAPHRAGM

PROCAM series maximum parameters		
Flow rate:	3	m ³ /h
Pressure:	80	bar
Product temperature:	80	°C



NOVADOS DOUBLE-ACTING HEAD SERIES

>Bran+Luebbe®



NOVADOS – DIAPHRAGM/PLUNGER METERING PUMP WITH HYDRAULICALLY BALANCED DIAPHRAGM

NOVADOS series maximum parameters		
Flow rate:	40	m ³ /h
Pressure:	1.000	bar
Product temperature:	150	°C

DOUBLE-ACTING PUMP HEAD

- Bran+Luebbe patented technology
- connection of two pump heads, the pump also doses by reverse run of the piston
- doubling the flow rate with the same footprint



NOVAPLEX – HIGH PERFORMANCE DIAPHRAGM/PLUNGER METERING PUMP WITH HYDRAULICALLY BALANCED DIAPHRAGM AND SPEED CONTROL

NOVAPLEX series maximum parameters		
Flow rate:	120	m ³ /h
Pressure:	1.000	bar
Product temperature:	150	°C



Mixers and agitators

Mixing

SPX provides a solution for any mixing application in your operation. We offer vertical, magnetic and side-entry agitators for dosing (batch) production for all types of tanks. For continuous production, we offer a wide range of static and dynamic mixers, with unique technical solutions.

Typical applications:

- mixing of two liquids
- forming a suspension
- homogenization
- particulate lift
- heat transfer
- aeration
- dissolving
- flocculation

>Lightnin®

Mixers and agitators



vertical agitators



magnetic agitators



side-entry agitators



static mixers



dynamic mixers



laboratory mixers



VERTICAL AGITATORS

Lightnin vertical agitators are available in various sizes from laboratory equipment to large refinery machines. All-stainless sanitary agitators and heavy-duty machines for hazardous environments.

Lightnin H Series

Economical and portable agitators for basic mixing applications in tanks up to 2.000 litres.

Benefits:

- economical design and fast delivery
- ATEX and air powered versions available
- weight to 10 kg for an easy installation
- mounting via clamp or flange
- 1-2 impellers (2 standard designs and 1 folding)
- solution for mixing IBC containers



LIGHTNIN H SERIES

H series parameters		
Power:	0,25	kW
Shaft length:	1,2	m

Lightnin ECL Series

Economical and portable agitators for basic mixing applications in tanks up to 2.000 litres.

Benefits:

- axial, radial, clean-edge and folding impellers
- mounting via clamp or flange (opened/closed tank)
- seals: packing gland seal, lip seal, mechanical (1x, 2x)



LIGHTNIN ECL SERIES

ECL series parameters		
Power:	0,25 – 4	kW
Shaft length:	1,2	m



Mixers and agitators

>Lightnin®

Lightnin Compact Series

New lightweight redesigned range of industrial agitators.

Benefits:

- true dry well with no risk of product contamination
- lower weight
- maintaining exceptional durability and overall resilience
- AGMA Quality 10 gear

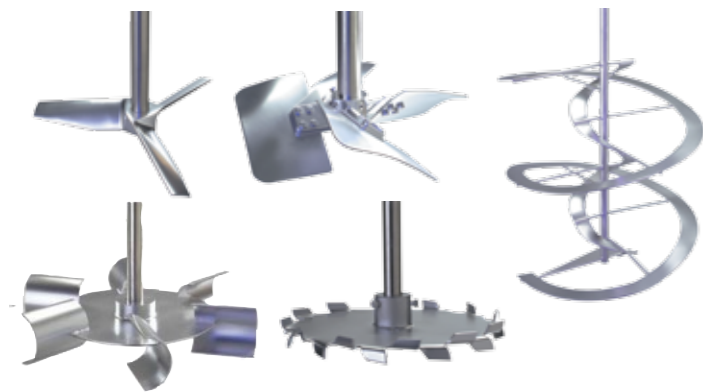

LIGHTNIN IMPELLERS



LIGHTNIN COMPACT SERIES



LIGHTNIN 10/70/80 SERIES

Lightnin Series 10/70/80

Medium-duty industrial agitators with a wide configuration and power range, meeting and exceeding AGMA standards.

Benefits:

- massive gearbox, bearings and reinforced shafts for higher load capacity and longer service life (L10 over 100.000 hours)
- ability to operate in tanks with temperatures up to 200 °C
- easy accessible mechanical seals from the top
- numerous certifications for worldwide use



LIGHTNIN 700/800 SERIES

Lightnin Series 700/800

The world's most powerful heavy-duty agitators for the most demanding applications.

Benefits:

- easy servicing thanks to accessible bearings
- unique design of shaft seating without transmission of bends to the gearbox
- bearings dimensioned high above AGMA standard

Lightnin medium/heavy-duty agitators series parameters

	Power [kW]		Power [kW]
Series 10	0,75 - 22,5	Series 700	0,75 - 22,5
Series 70	0,75 - 150	Series 800	0,75 - 150
Series 80	1 - 150	Compact	0,75 - 55



Mixers and agitators

>Lightnin®

Lightnin Nettco-S

Affordable hygienic all-stainless steel agitators with 3A certification for basic applications in the food and pharmaceutical industry.

- mounting via clamp or flange

Nettco-S series parameters

Power:	0,18 - 2,2	kW
Shaft length:	2,1	m



LIGHTNIN SANSTAR SERIES



LIGHTNIN NETTCO-S SERIES

Lightnin SanStar

Compact all-stainless steel agitators for the cleanest operations.

- shaft diameters from 19 to 38 mm
- polished surfaces including drive for easy cleaning
- wide selection of Lightnin impellers
- for tanks up to 20.000 litres
- offset drive version to eliminate unwanted frequency band

SanStar series parameters

Power:	0,18 - 2,2	kW
Shaft length:	4,5	m



MAGNETIC AGITATORS

The most hygienic aseptic mixing of tanks for the pharmaceutical industry.

Lightnin MagMixer MBI & MBE

Benefits:

- long shaft elimination
- torque up to 300 Nm
- for tanks up to 60.000 litres
- aseptic connection
- ensuring product homogeneity even during draining
- dry running option
- viscosity up to 500 cP
- Hyper-Flo easy replaceable patented bearings
- 360° swivel drive for ideal positioning under the tank
- fully CIP/SIP cleanable
- all-stainless steel drives available
- ATEX certified

MagMixer MBI & MBE series parameters

Power:	0,09 - 7,5	kW
--------	------------	----



LIGHTNIN MAGMIXER MBE





Mixers and agitators

SIDE-ENTRY AGITATORS

Plenty side-entry agitators are known worldwide as reliable, heavy-duty agitators for large tanks and tanks in refineries. In addition to these large, dimensional agitators, Plenty also offers a wide range of compact agitators suitable for use in small tanks.

Side-entry agitators with fixed angle blades

Benefits:

- robust, heavy-duty design
- minimal maintenance requirements
- belt/gear drive
- diameter of impeller from 400 to 840 mm
- applications: mixing of petroleum products, crude oil and other applications in the chemical industry

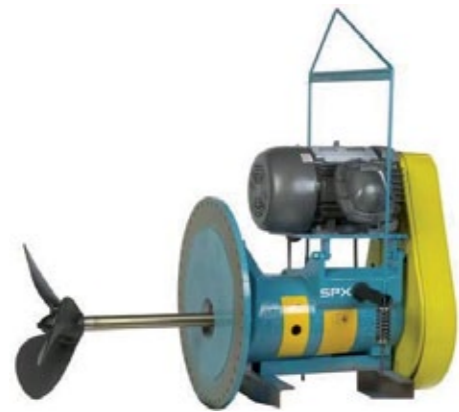

AGITATOR WITH ADJUSTABLE ANGLE BLADES

Agitators with adjustable angle blades

Benefits:

- diameter of impeller from 400 to 840 mm
- automatic drive option for easy angle adjustment

Plenty agitators parameters

Power:	55	kW
--------	----	----



TMH SERIES

>Plenty®



AGITATOR WITH FIXED ANGLE BLADES

TMH series

Benefits:

- compact, robust design
- highly efficient impeller design for optimal mixing and energy saving
- all wetted components made of SS316 stainless steel
- simple bearings and seal replacement without the need to empty the tank
- special bearing fixing prevents deflection of the seal
- connection to the tank via 4" ANSI flange
- power range from 1,1 to 5,5 kW



Mixers and agitators

STATIC MIXERS

APV TPX, Lightning 45, Bran+Luebbe N-Form

Benefits:

- affordable mixing solution with no need for a tank
- dimension: DN15 - DN300
- sanitary and industrial versions and connections
- material selection: 316L stainless steel, Hastelloy, PTFE lining

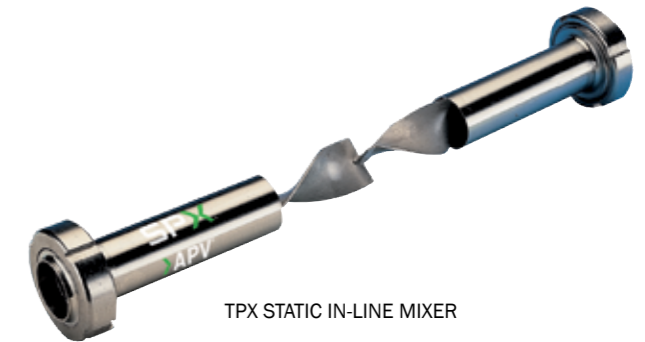

TPX STATIC IN-LINE MIXER

DYNAMIC MIXERS AND SYSTEMS

APV DMF Mixer

Dynamic mixer specially developed for efficient mixing of yoghurt and cottage cheese. Horizontal or vertical design.

Capacity: 100 - 6.000 l/h



DMF MIXER

APV DarMix+ In-line Mixer

Compact dynamic blender with high efficiency for butter, mayonnaise, dressings, sauces and dips production.

Dimension: DN80 a DN100

Capacity: 3.000/6.000 l/h



DARMIK+ IN-LINE MIXER

Bran+Luebbe Pentax KMF/SMD

The most advanced SPX dynamic mixer with the highest mixing efficiency for industrial and food applications.

Pentax KMF: horizontal version with highest product homogeneity

Pentax SMD: vertical version with EHEDG certification, hygienic seal and complete drainability

Dimension: DN25 - DN150

Capacity: 40 - 50.000 l/h

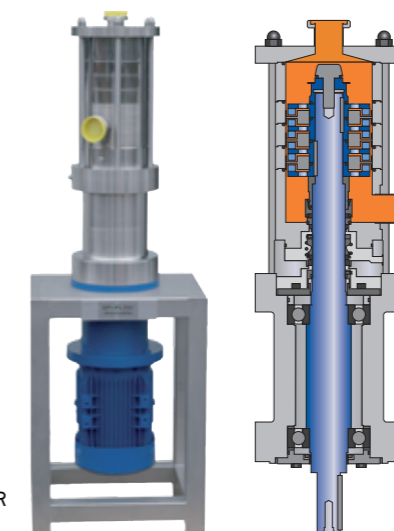

PENTAX SMD DYNAMIC MIXER

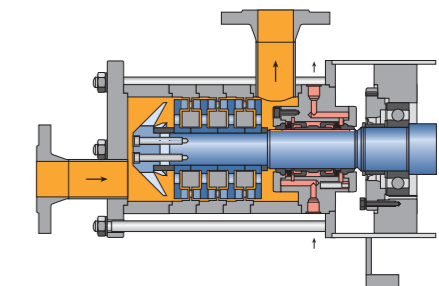

PENTAX KMF DYNAMIC MIXER



Mixers and agitators



Waukesha Colloid mills

High speed mills for particle size reduction and intensive emulsification in the production of sauces, mayonnaise or personal care products.

- unrivalled low product heating

Capacity: 1.500 – 7.500 l/h

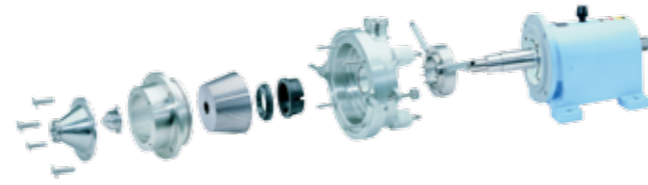

WAUKESHA COLLOID MILL

APV Cavitator

A revolutionary device using the principle of controlled cavitation (thanks to a perforated drum), which blends phases down to the molecular level! At the same time, there is an intensive heat development throughout the entire volume, which can also be used for easy controllable pasteurization of demanding products.

Other benefits:

- unmatched results in mixing and homogenization of compounds (molecular blending)
- mixing the liquid with any other phase (gas, liquid, solid particles)
- intense heat transfer without temperature gradient
- heating and mixing control by frequency converter
- full CIP cleanability

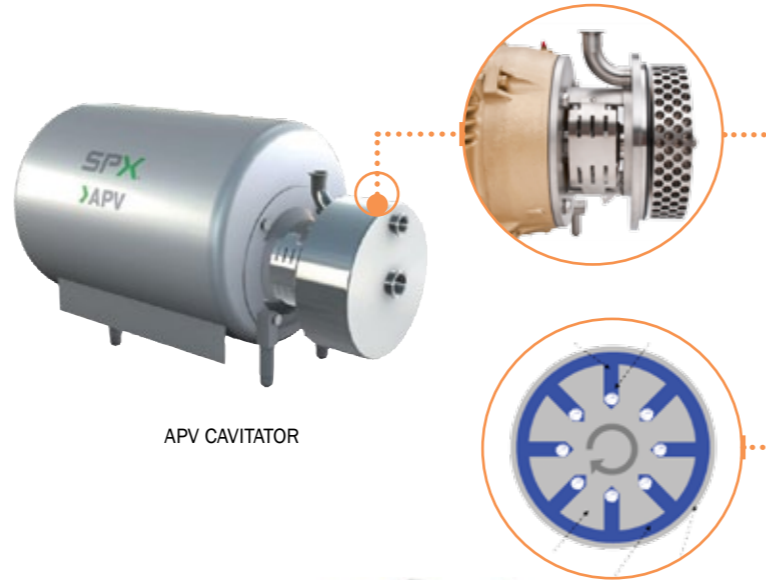

APV CAVITATOR

Capacity: up to 20.000 l/h

APV Flex-Mix Power

Aseptic in-line mixer for emulsification (liquid/liquid) and dispersion (liquid/gas) applications.

Capacity: 250 – 5.100 kg/h



FLEX-MIX POWER

APV Flex-Mix Processor

Mixing system with collapsible duplicated tank, integrated dynamic mixer, slow-running agitator and circulation line with pump for a very gentle mixing of solids into the liquid.

- full CIP cleanability, steam nozzles for heating (optional)
- possibility of adding vacuum

Batch size: 250 – 3.000 litres



FLEX-MIX PROCESSOR



Mixers and agitators



APV Flex-Mix TPM+

Simple in-line mixer with Venturi principle and a hopper for mixing powder into low viscosity liquid. A popular solution for adding sugar and other powders to milk.

Characteristics:

- TPM+1 (12.500 - 25.000 l/h + max. 60 kg/min)
- TPM+2 (25.000 - 50.000 l/h + max. 150 kg/min)
- max. viscosity of the final product: 800 cP
- direct air inlet to the product
- ideal for sweetening milk, recombined milk



APV FLEX-MIX TPM+

APV Liquiverter

Batch mixer with vortex principle for mixing powders in low and medium viscosity liquids.

Characteristics:

- tank sizes from 250 up to 3.000 litres
- square container without buffers
- air inlet into the mixture
- for medium concentration of powders
- integrated knife option
- shear rate up to 36.000/s
- ideal for ice creams, recombined products and strongly sweetened beverages



APV LIQUIVERTER

APV Flex-Mix Instant

Vacuum mixer for the best results without air admixture. The vacuum principle allows the use for more viscous liquids and higher proportions of powder.

Characteristics:

- 500 - 10.000 litre tanks
- the best current mixing technology
- patented powder suction system
- vacuum mixing with short hydration time
- shear rate up to 92.000/s



APV FLEX-MIX INSTANT



> Seital® Separation

Seital centrifugal separators

Centrifugal separators are an indispensable part of the dairy and brewery industry. They are also becoming increasingly popular in other industries. By centrifugal acceleration, they dramatically speed up the natural process of separating components in the medium. The manufacturer Seital of the SPX group is one of the absolute leaders in this segment, thanks to the best efficiency, materials and overall design of the equipment.

General features of Seital centrifugal separators:

- duplex or super-duplex bowl materials
- up to 11.000 rpm
- up to 17.770x faster component separation
- Direct-drive option with compact footprint, lower power consumption and longer service life
- safe filling of the separator from the top
- variants with manual emptying or automatic self-cleaning

According to the function of the device, separators can be supplied in all common configurations:

- clarifier – cleaning of liquid from solid particles
- separator – separation of two liquid phases
- concentrator – separation of two liquids with a predominance of heavy phase
- purifier - separation of two liquids with a predominance of the light phase

All Seital centrifugal devices can be supplied in various levels of automation, from simple devices with manual solids cleaning to fully automated devices, including complete commissioning and HW/SW connection.



SIMPLE SEPARATOR WITH MANUAL BOWL CLEANING



SEPARATOR WITH AUTOMATIC CLEANING AND PRIMING PUMP



DIRECT DRIVE SEPARATOR

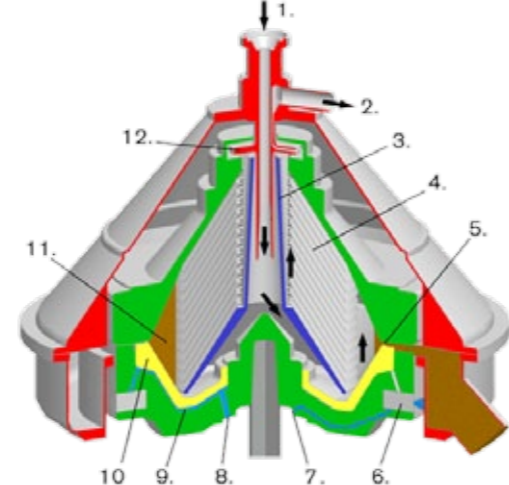

CLARIFIER – BOWL DETAIL

1. PRODUCT INLET | 2. PRODUCT OUTLET | 3. DISTRIBUTOR
4. DISC ASSEMBLY | 5. SOLIDS REMOVAL
6. BOWL VALVE | 7. WATER INLET FOR OPENING
8. WATER INLET FOR CLOSING | 9. CLOSING WATER CHAMBER
10. CLOSING ARM | 11. SEPARATED PARTICLES
12. PUMP BLADES



> Seital® Separation

Centrifugal clarifiers for breweries

For breweries, Seital offers a solution for streamlining production, typically beyond 2.000 hl/year.

- unique hermetic design
- unrivaled prevention of oxygen ingress (5 - 10 ppb guaranteed!)
- gentle beer flow and maximum product quality
- the best solution on the market for all clarification processes in the brewing industry

Centrifugal separators and clarifiers for the dairy industry

We offer solutions for all common applications in the dairy industry:

- milk clarification at intake
 - solutions for cold and hot clarification (2.500 - 65.000 l/h)
- bactofugation of milk – removal of up to 95% of thermoresistant spores from pasteurized milk
 - with bacteria recirculation system for minimal product loss (0.04 - 0.06%)
- milk separation - residual fat content only 0.03 - 0.05% (Gerber)
- clarification and subsequent whey separation

Milk and cream standardization

AxFlow supplies complete milk and cream standardization systems from SPX. The standardization can be integrated into the separator unit or supplied separately to an existing separator.



STANDARDIZATION INTEGRATED INTO THE SEPARATOR SKID



AUTOMATIC SEPARATION SYSTEM IN THE BEVERAGE INDUSTRY



DIRECT DRIVE SEPARATOR WITH MILK STANDARDIZATION



SEPARATE MILK STANDARDIZATION UNIT



Valves



APV valves

APV valves are known for their robust design and hygienic design. They are widely used mainly in the food and pharmaceutical industries due to their ability to ensure safe handling of the processed product. They can withstand the CIP process and not only because they are made of 316L grade stainless steel. Most valves have EHEDG and 3-A certification, including FDA certified elastomers.

They have their place in automated processes and can be operated manually or by compressed air. They meet the requirements of industrial automation thanks to special control units composed of a pneumatic actuator, sensors and indication diodes. They are fully integrated into your process and always under your control.

APV offers these types of valves



butterfly valves



ball valves



seat valves



safety valves



check valves



sampling valves



regulation valves

BUTTERFLY VALVES

APV DELTA SV & SVS

Robust and hygienic shut-off valve for food processing plants.

Benefits:

- materials: SS316L or SS304
- surface: Ra 1,6/0,8/0,5
- seal materials: EPDM, HNBR, Viton, Silicone
- process connection options: welding, clamp, DIN 11851, SMS, hygienic flange
- manual and pneumatic design (including control unit)
- top and bottom bearings for extended service life
- possibility to use in vacuum technology
- metal buffer to prevent extensive torque of flanges during assembly and seal damage
- SV: basic version, SVS: version with compact mid flange



THREE CONTROL OPTIONS OF THE SV/SVS VALVES



APV DELTA SVS

DETAIL OF THE VALVE MECHANISM

SV & SVS series maximum parameters		
Dimensions:	DN25 - DN250	
Pressure:	10	bar
Temperature:	140	°C



Valves



BALL VALVES

APV DELTA BLV

Simple ball valve in hygienic design.

Benefits:

- materials: SS316/L
- surface: Ra 0,8
- compatible with DIN 11850/ISO pipeline
- seals materials: PTFE (FDA approved)
- welding or clamp connection
- manual and pneumatic design (including control unit)
- manual design with feedback or locking option
- fully flowing valve when open

BLV series maximum parameters

Dimensions:	DN15 - DN100	
Pressure:	10	bar
Temperature:	160	°C



THREE CONTROL OPTIONS OF THE VALVES

APV DELTA DKR

Advanced version of the hygienic ball valve with mixproof design and integrated CIP/SIP connection and drainage.

Benefits:

- materials: SS316/L
- surface: Ra 0,8
- seal materials: PTFE (FDA approved), EPDM flange, Viton, HNBR, Silicone
- ideal solution for pigging applications
- DKRH high-pressure version for pressures up to 100 bar
- DKRT discharge version for tank drainage



APV DELTA DKRH

APV DELTA DKR



APV DELTA DKRT

DKR series maximum parameters		
Dimensions:	DN25 - DN100	
Pressure:	10/100	bar
Temperature:	140	°C



Valves

SEAT VALVES

APV offers the widest portfolio of hygienic seat valves.

Common parameters of APV seat valves:

Material: SS316L
 Seals: EPDM, Viton, HNBR, Silicone, PTFE
 Surface: Ra 0,8/0,5
 Dimensions: from DN10 (SWmini4, AP1)
 from DN25 (SW4, SWcip4, MS4, SD4)
 from DN40 (D4, DA4, DA3+, DE3)
 Temperature: 135 °C/140 °C (short-term for SIP)
 Pressure: 10 bar
 Certifications: 3-A, EHEDG, ATEX



APV DELTA SD4 & SDM4

Single seat APV valves

Hygienic and robust solution for closing and switching pipelines, as well as for the most hygienic tank drainage.

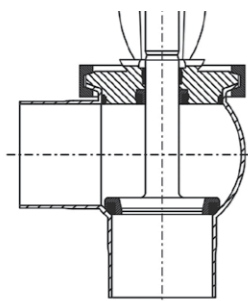

shut-off function

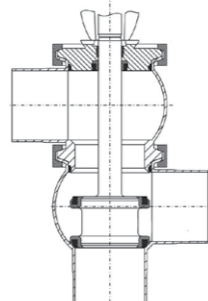

diverting function

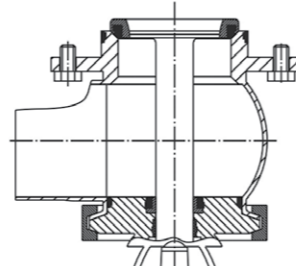

tank draining function

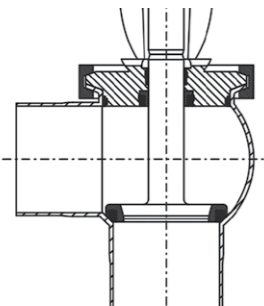

APV DELTA SW4/SWmini4
(basic version)

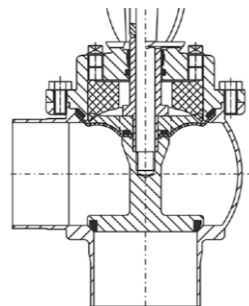

APV DELTA MS4
(aseptic version)

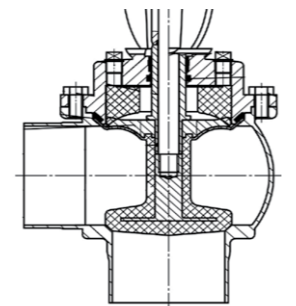

APV DELTA MSP4 / AP1
(aseptic version + PTFE coating)

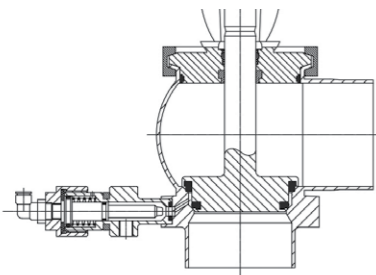

APV DELTA SWcip4

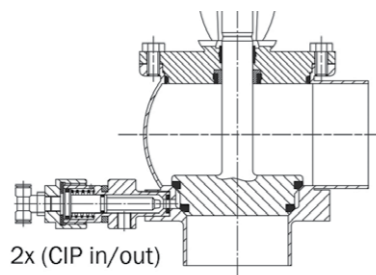

2x (CIP in/out)

APV DELTA SD4

(mixproof version + CIP chamber cleaning)

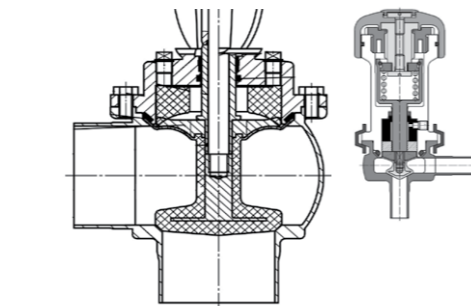

2x (CIP in/out)

APV DELTA SDMS4

(aseptic mixproof version + CIP chamber cleaning)



Valves

SEAT VALVES

Double seat APV valves

The most perfect solution for product pipelines with CIP cleaning.

Benefits:

- two independently controlled seats
- continuous operation with two mediums (product + CIP) in the valve without risk of contamination
- seat lift for cleaning
- minimum loss of CIP product
- easy integration into the valve terminal for a complete CIP operation



VALVE TERMINAL FOR CIP CLEANING



APV DELTA DT4
(version for a tank bottom integration)



APV DELTA D4/D4SL
(basic version/seat lift version)



APV DELTA DA4
(ultra hygienic version with minimal CIP waste)



Control units

CU4, CU4+, CU3 Control Unit

Control units for all butterfly, ball and seat valves.

Benefits:

- speed up installation and start-up
- clear and bright LED status indication, IP67 protection
- ATEX option
- 1 to 3 solenoid valves with manual switch option
- adjustable opening/closing speed
- power supply voltage: 15 - 48 VDC
- communication: 24VDC/110VAC/AS-i/PROFIBUS/i-O link
- 2 internal and 2 external sensors for valve position detection
- air pressure 6 - 8 bar (g)



CU4 DIRECT CONNECT UNIT



Valves

SAFETY VALVES

Spring-loaded safety valves with hygienic design for CIP plants

Parameters:

- dimensions: DN25 – DN100
- material: SS316L; Ra 0,8
- temperatures: up to 135 °C
- seal materials: EPDM, Viton, HNBR, Silicone
- ability to lift the seat with compressed air or manually

APV DELTA SI2: TÜV approved safety valve for 6-10 bar

APV DELTA UF: bypass valve with adjustable opening pressure (0-10 bar)

APV DELTA UFR: UF series modification for constant pressure function

APV DELTA VRA/H: vacuum valves for monitoring excessive vacuum pressure (DN50 - DN150)



APV DELTA SI2

APV DELTA UF/UFR

APV DELTA VRA/VRAH

CHECK VALVES

Hygienic check valves prevent fluid backflow with minimal pressure loss and easy cleanability (3-A certified).

Parameters:

- dimensions: DN25 – DN150
- material: SS316L; Ra 0,8
- seal materials: EPDM, Viton, HNBR, Silicone
- pressure: up to 10 bar

APV DELTA VPN: economical design

APV DELTA RUF3: robust design with profiled seals and easy servicing



APV DELTA VPN

APV DELTA RUF

SAMPLING VALVES

Hygienic valves for easy sampling from tanks or pipelines.

Parameters:

- dimensions: DN25 – DN100
- material: SS316L; Ra 0,8
- PTFE valve cone
- in-line sampling or connection to the tank
- manual and automatic design including feedback function

APV DELTA PR2: standard version

APV DELTA PRD2: version with steam sterilization connection (SIP)



APV DELTA PR



Valves

REGULATION VALVES

To ensure constant process flow and pressure.

APV DELTA RG & RGE & RGMS

Benefits:

- linear valve characteristic for large flow rates and small pressure differentials
- linear or equal percentage characteristics
- for small flow rates and large pressure differences
- integrated or NAMUR SAMSON positioner
- aseptic version available

Parameters:

- dimensions: DN25 - DN150
- material of wetted/unwetted parts 316L/304 stainless steel
- PTFE diaphragm
- process connection options - welding, hygienic flange

RGE4: economical design with fixed Kv coefficient and NAMUR positioner

RG4: modular design with changeable Kv coefficient and integrated positioner

RGMS4: aseptic version of RG4 valve

RGE/RG/RGMS series maximum parameters

Pressure range:	10 – 25	bar
Product temperature:	135	°C

APV DELTA CPV

A diaphragm valve that maintains a constant pressure in pipeline systems. The valve opens when the pressure rises and closes when the pressure drops.

Benefits:

- robust, durable flat membrane
- drip detection
- ideal for CIP cleaning due to flat diaphragm and smooth valve body surface

Parameters:

- dimensions DN25 or DN50
- PTFE TFM or EPDM diaphragm materials
- process connection - welding

CPV series maximum parameters

Pressure:	10	bar
Product temperature:	135	°C



APV DELTA RG4



APV DELTA RGE4



APV DELTA CPV



Filters

Waukesha
Cherry-Burrell

Waukesha hygienic filters

Corner and in-line filters for hygienic applications.

Benefits:

- material: SS316L
- dimensions: 1" to 4"
- two optional capacities in each dimension
- connection: clamp, DIN thread, SMS or welded
- filter insert fineness: up to 43 microns
- filter insert material: SS316L, cotton, nylon, viscose
- elastomers: EPDM, Viton, Buna, Silicone



WAUKESHA CORNER AND IN-LINE FILTERS

Series maximum parameters		
Pressure:	14	bar
Filtration:	43	microns

Airpel suction filters and pipe baskets

Robust filters with one or two baskets, high capacity and self-cleaning.

Benefits:

- materials – body: SS316, steel, cast iron, bronze
– baskets: SS316
- dimensions: 3/4" to 6"
- flange connection: ANSI, DIN, BS10, BS4504
- thread connection: BSP, NPT
- filtration up to 10 microns
- baskets with large filtration area and low pressure loss
- operating pressure up to 50 bar

Accessories: filter clogging sensor, heated jacket, magnetic inserts, automatic venting



AIRPEL FILTERS

Series maximum parameters		
Pressure:	50	bar
Filtration:	10	microns

Airpel



Heat exchangers

Plate and scraped surface heat exchangers

A heat exchanger is a device that transmits heat between two media. They are widely used in chemical, petrochemical and power plants, as well as in the food industry. There are many types of heat exchangers, whose use depends on the characteristics of the medium, the cleaning requirements and the parameters of the process itself.

Scraped surface heat exchangers

- tubular construction, with a motor driven shaft with wiper blades inside
- cooling/heating, controlled crystallization or aseptic sterilization of highly viscous and inhomogeneous products that are wiped off the exchanger wall by wiper blades

Plate heat exchangers

- consist of thin separated plates, which provide a large heat exchange surface and yet they are very compact
- ideal for low-viscosity, low-particulate media, high efficiency



Scraped surface heat exchangers

Waukesha
Cherry-Burrell

Waukesha Votator II

For in-line cooling, heating, controlled crystallization, polymerization, plasticization and aseptic sterilization of viscous and inhomogeneous products not only in the food industry. Available individually or as part of a system.

Characteristics: rotary scraped surface heat exchanger with centric, eccentric or oval geometry, duplicated heating jacket and high load wipers

Other benefits:

- materials: SS316L, sanitary design
- compact construction for vertical or horizontal mounting
- high heat transfer efficiency
- single and double mechanical seals
- heat exchange surface 0,28 - 1 m² per cylinder (degree)

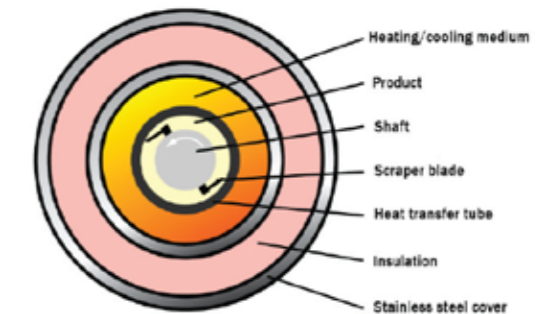

CUT THROUGH THE SCRAPED SURFACE HEAT EXCHANGER

Votator II series maximum parameters		
Viscosity:	1.000.000	cP
Flow rate:	9	m ³ /h
Pressure:	41	bar
Temperature:	210	°C



VOTATOR II

VOTATOR LD



Plate heat exchangers



APV gasketed plate heat exchangers

Plate heat exchangers for industrial or hygienic use.

Benefits:

- plate materials: SS304, SS316L, Titan
- the largest selection of plate shapes on the market
- applications in the food, pharmaceutical, chemical and energy industries
- designed for efficient CIP application, easy removal of deposits and sediments
- efficient design of the heat transfer surfaces reduces the formation of deposits
- stainless steel or painted frame option
- ParaWeld: optional semi-welded design for aggressive fluids and refrigerants
- DuoSafety: optional double plates for extra safety in pharmaceutical applications



APV PLATE HEAT EXCHANGERS

Maximum parameters		
Flow rate:	4.500	m ³ /h
Pressure:	35	bar
Temperature range:	-45 to 250	°C

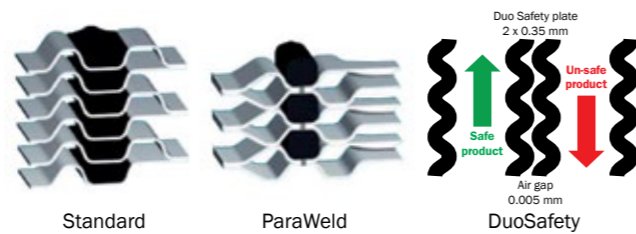

Brazed plate heat exchangers

Plate heat exchangers with brazed connection instead of mechanical seals.

Benefits:

- economical solution
- compact size
- fast delivery
- no need to replace the seal
- material: Cu, Ni, PureInox (SS)
- easy integration into systems



APV BRAZED PLATE HEAT EXCHANGERS

Maximum parameters		
Pressure:	30	bar
Temperature range:	-50 to 195	°C

Portfolio of other products by category



Plate heat exchangers

euro heat

Euro Heat plate&shell heat exchangers

All-welded heat exchangers for heavy-duty applications in the chemical and petrochemical industries.

Benefits:

- plate materials: AISI 304, AISI 316L, Hastelloy C-276, titanium
- shell materials: carbon steel, AISI 304, 316
- extreme temperatures from -200 °C to 500 °C
- operating pressure up to 100 bar
- high efficiency up to 95%
- connection size: DN 25 - DN 200
- ideal for oil & gas applications
- very good cleanability
- high safety and reliability



PLATE&SHELL HEAT EXCHANGERS

Maximum parameters		
Flow rate:	700	m ³ /h
Pressure:	100	bar
Temperature range:	-200 to 500	°C

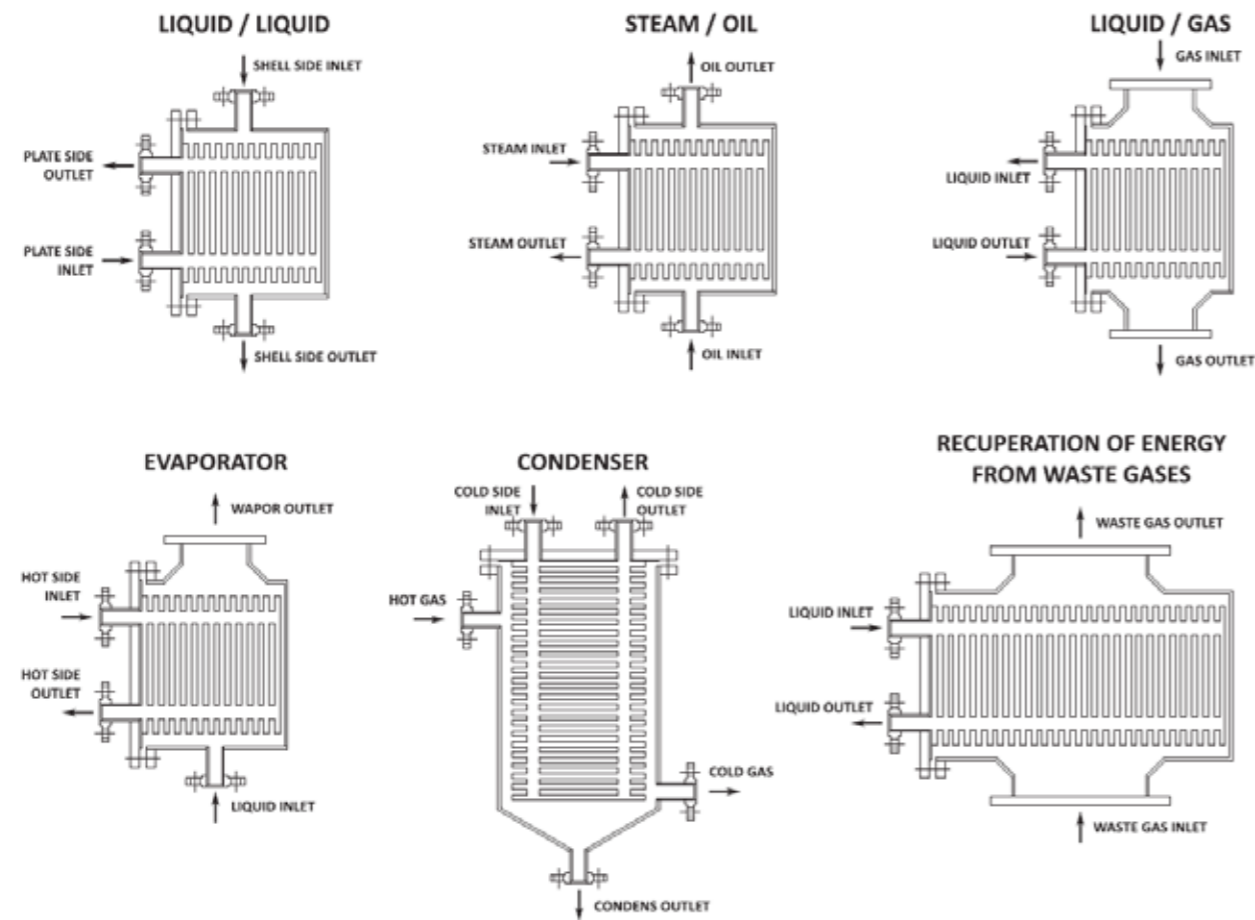

TYPICAL APPLICATIONS



AODD pumps

Sandpiper compressed air-operated diaphragm pumps

SANDPIPER

Characteristics: self-priming, chemically resistant, dry running, ability to pump abrasive liquids

Other benefits:

- materials: PP, PVDF, SS316, Hastelloy-C, aluminium, cast iron
- self-lubricating maintenance-free air control
- special design for high pressures, butterfly valves, external valve chamber
- connection size: 1/4" to 4"



HEAVY-DUTY NON-METALLIC FLAP

Maximum parameters		
Flow rate:	60	m ³ /h
Pressure:	17	bar
Product temperature:	177	°C

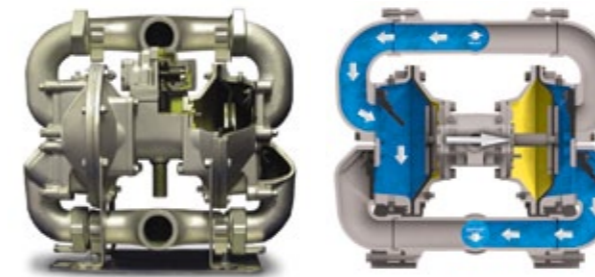

HEAVY-DUTY METALLIC FLAP

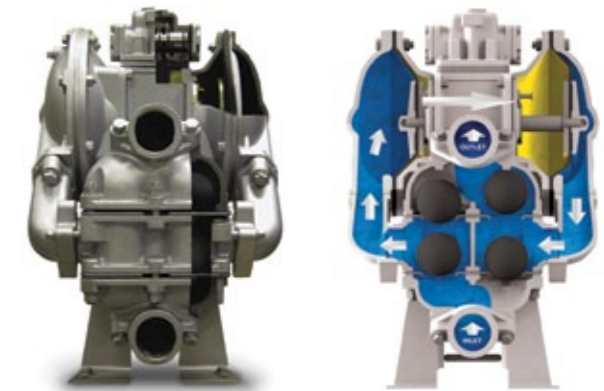

HEAVY-DUTY BALL

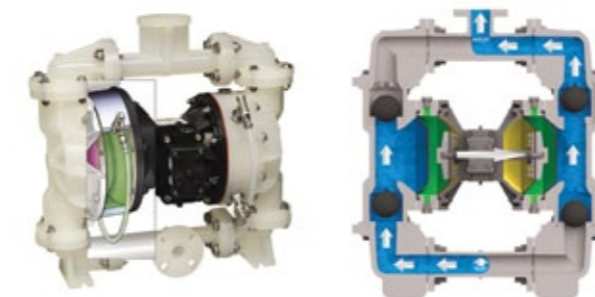

CONTAINMENT DUTY SERIES WITH DIAPHRAGM RUPTURE DETECTION



PULSATION DAMPER

Wide selection of spare parts for all brands of air diaphragm pumps

AODD aftermarket parts - quality equivalent parts at attractive prices also for pump brands:

ARO, BLAGDON, DEPA, FLUX, GRACO, VERDEAIR, VERSA-MATIC, WILDEN, YAMADA





Peristaltic pumps

ABAQUE heavy-duty peristaltics pumps

Characteristics: sealless, self-priming, chemically and abrasive resistant, dry running, reversible, cleanable

Other benefits:

- rotors cast from ductile iron
- robust drive design with reinforced bearings
- helical and planetary gearboxes
- hygienic design option
- continuous run up to 16 bar
- suction lift up to 9,5 m
- pumping of sensitive, viscous and abrasive products
- easy hose change
- possibility to change shims without having to disassemble the lid
- SS316, PVDF or PPh stainless steel inserts
- ATEX certified for zone 1 or 2



INDUSTRIAL DESIGN

Maximum parameters		
Flow rate:	54	m ³ /h
Pressure:	16	bar
Product temperature:	90	°C



PUMP CHAMBER DETAIL

Accessories for ABAQUE peristaltics pumps:

- lubricants, pulsation dampers, hose damage sensors, vacuum kits for improved suction of viscous fluids



ABAQUE PERISTALTIC PUMP CONSTRUCTION



HYGIENIC DESIGN

Hose for ABAQUE pumps:

- turned hoses DN 10 – DN100 (NR, NR-FDA, NR ATEX, NBR, NBR-FDA, EPDM, EPDM ATEX, Hypalon)
- economical hoses DN 10 – DN100 (NR, NBR, NBR-FOOD, EPDM, CSM/Hypalon)



ABAQUE HOSES



Peristaltic pumps

RealAx APY

Simple and affordable pumps for simple dosing applications.

Benefits:

- three roller design for lowest vibrations
- very simple and easy hose replacement
- suction lift up to 6 m
- ATEX certified
- up to 150 rpm

Hoses for RealAx pumps:

- 0,8 - 8,0 mm (Silicone, Santoprene, Tygon, Norprene, Solva, Stapure, Chemsure)



REALAX APY

Maximum flow rate of the RealAx APY series							
	APY 0.8	APY 1.6	APY 3.2	APY 4.8	APY 6.4	APY 8.0	
Flow rate:	0,16	0,4	1,7	3,8	6,3	10	ml/rpm.

Blue-White

Blue-White FlexFlo M

Extremely precise dosing pumps with integrated control.

Benefits:

- perfect solution for filling and dosing applications
- aluminium body and high IP66 protection
- multichannel pumping option
- minimal pulsations
- integrated control display
- high dosing accuracy
- brushless DC motor
- suction lift up to 9 m
- control option 4 - 20 mA, 0 -10 VDC, pulse or manual on the pump display
- super large control range up to 10.000:1
- load-sure element as standard
- automatic hose change monitoring, dose size counter

Hoses for Blue-White pumps:

- Flex-A-Prene, Flex-A-Chem, Flex-A-Thane



BLUE-WHITE FLEXFLO M3

FlexFlo M series maximum parameters						
	M1	M2	M3	M4	M5	
Flow rate:	21,2	80	126	600	2021	l/h
Pressure:	6,9	8,6	8,6	8,6	4,4	bar



Metering pumps

Blue-White

Blue-White Chem-Feed MC

Compact diaphragm pumps with PVDF head and integrated control for precise dosing.

Benefits:

- excellent chemical resistance thanks to PVDF and ceramic materials
- accuracy +/- 2 %; repeatability +/- 0,5 %
- Hastelloy C-276 valve springs
- reinforced front with stainless steel plate
- threaded or hose connection
- integrated control
- diaphragm rupture detection
- remote control and flow measuring functions
- suction lift up to 4,5 m
- IP66 protection



BLUE-WHITE CHEM-FEED MC2

Chem-Feed MC series maximum parameters

	MC2	MC3	
Flow rate:	62,5	154	l/h
Pressure:	12	12	bar
Turndown ratio:	200:1	200:1	

Blue-White Chem-Feed MD

Precise metering pumps with two diaphragms and brushless motor drive for lower pulsations and excellent dosing range.

Benefits:

- excellent chemical resistance thanks to PVDF and ceramic materials
- reinforced front with stainless steel plate
- Hastelloy C-276 valve springs
- threaded or hose connection
- brushless DC drive
- integrated control
- diaphragm rupture detection
- remote control and flow measuring functions
- excellent suction lift up to 7 m
- IP66 protection



BLUE-WHITE CHEM-FEED MD3

Chem-Feed MD series maximum parameters

	MD1	MD3	
Flow rate:	32,2	199	l/h
Pressure:	10,3	10	bar
Turndown ratio:	10.000:1	2.000:1	



Metering pumps

Wanner Hydra-Cell multi-diaphragm pumps

Characteristics: robust pumps for high-pressure pumping, dry running, ability to pump abrasive fluids, accuracy +/- 1%, linearity +/-3%, repeatability +/- 3%

Other benefits:

- materials: SS316, cast iron, brass, PP, PVDF, Hastelloy-C, Kalrez
- multi-diaphragm, piston, sealless pump with high efficiency
- minimal vibrations during running
- high operational safety
- Kell-Cell – anti-cavitation system - prevention of pump damage by cavitation
- hydraulic diaphragm drive - high durability
- process and dosing design
- connection size: 1/2" to 2 1/2"
- dosing series P, T and Q series meeting API 674 standard

Accessories:

safety, bypass and vent valves, oil cooler, pulsation dampers, control unit with control panel for precise dosing



HYDRA-CELL P SERIES - FOR PRECISE DOSING

P series maximum parameters

Flow rate:	3	m ³ /h
Pressure:	172	bar
Product temperature:	120	°C

WANNER HYDRA-CELL SEAL-LESS PUMP TECHNOLOGIES



HYDRA-CELL G SERIES

G series maximum parameters

Flow rate:	15	m ³ /h
Pressure:	172	bar
Product temperature:	120	°C

Industrial applications:

The robust design and material options of the pump (e.g. Kalrez diaphragms) make them ideal for demanding chemical, petrochemical applications and mining industry.



HYDRA-CELL Q SERIES (QUINTUPLEX)

HYDRA-CELL T SERIES (TRIPLEX)

T/Q series maximum parameters

Flow rate:	35,7	m ³ /h
Pressure:	345	bar
Product temperature:	120	°C



Metering pumps

Wanner Hydra-Cell MT8

Piston-diaphragm pumps for high pressures and low flow rates.

MT8 series maximum parameters		
Flow rate:	0,3	m ³ /h
Pressure:	350	bar

Wanner accessories

Wanner offers a range of original accessories for maximum safety in high-pressure dosing:

- safety valves
- check valves
- vent valves
- pulsation dampers

Materials: SS316, PP, PVDF, Nickel, Brass, Hastelloy C, PTFE, Alloys

Connection: 1/4" to 2"



MT8 SERIES - LOWEST FLOW RATES AND HIGH PRESSURES



WANNER SAFETY VALVES



Progressive cavity pumps

Mono NOV progressive cavity pumps

Characteristics: self-priming, pulseless, gentle pumping, high-pressure version, high-efficiency pumping

Other benefits:

- materials: cast iron, SS316, SS316L
- designed for industrial pumping applications of viscous and abrasive liquids
- dimensions: DN 25 up to DN 200
- EZSTRIP version with easily removable chamber for easy servicing without the need to disassemble the pipeline

COMPACT	pump with simpler joint design with increased durability
EPSILON	heavy-duty pump with Flexishaft
WIDETHROAT	pump with rectangular hopper and screw feeder for high-viscosity non-flowing media (dewatered sludge, paste, puree, etc.)
API 676	pump meeting API 676 standard
HYGIENIC	hygienic CIP cleanable pumps

MONO FLEXISHAFT

- patented Mono flexible shaft that handles eccentric movement without the need for complicated shaft seating
- significantly longer rotor life
- no shaft lubrication required - no product contamination



EPSILON SERIES WITH FLEXISHAFT



Progressive cavity pumps



EZSTRIP™ QUICK SERVICE PUMP VARIANT



Maximum parameters		
Flow rate:	420	m ³ /h
Pressure:	24	bar
Product temperature:	90	°C



L SERIES METERING PUMPS FOR FLOW RATES UP TO 1250 L/H



UNIVERSAL PARTS

HIGH QUALITY SPARE PARTS FOR PUMPS SEEPEX, NETZSCH, PCM, ALWEILER, ROBBINS & MYERS, BORNEMANN, ORBIT, MOYNO

Mono NOV Hygienic

New range of hygienic progressive cavity pumps in several designs for food and pharmaceutical applications.

Benefits:

- dimensions DN40 – DN150
- transfer solids up to 25 mm
- fully drainable design
- CIP cleaning
- hygienic connections: DIN 11851, Clamp, DIN 11864/53-1, SMS
- standard, cartridge or 3A/EHEDG hygienic seals
- very gentle pumping
- high suction lift
- abrasion-resistant and FDA certified stators
- stainless steel engine cover option
- wetted parts made of 316 L stainless steel with surface fineness below Ra 0,8
- 3 pump variants: basic hygienic version, 3A version, EHEDG version
- Titanium Flexishaft



MONO NOV HYGIENIC

NOV Hygienic series maximum parameters

Flow rate:	92	m ³ /h
Pressure:	16	bar



Munchers and grinders

NOV Munchers

NOV munchers are a proven choice for WWTPs and biogas plants thanks to their robust design, simple service and easy integration into pipelines, channels and technologies.

Mono NOV Series A

Proven channel and pipeline munchers with slow-running crushing.

Benefits:

- simple cast iron design
- unique Mono ETOS cutters
- installation in a concrete channel or pipeline
- slow running (85 rpm) with low power consumption
- overload protection with reverse run
- ATEX certified



MONO NOV SERIES A

Mono NOV EZstrip TR

Innovative pipe munchers with a trap pocket for impassable material and easy servicing.

Benefits:

- unique Mono ETOS cutters
- pipeline installation
- easy two-sided access to the cutters
- trap pocket for non-passable material
- overload protection with reverse run
- ATEX certified



MONO NOV EZSTRIP TR

NOV Chopper Hopper

Compact skid for energy processing of bio-waste in biogas plants.

Benefits:

- large capacity hopper for coarse crushing
- screw conveyor and fine grinding (1-2 levels)
- outlet progressive cavity pump
- compact design
- cast iron or stainless steel design
- fast on-site start-up
- ATEX certified



NOV CHOPPER HOPPER



Piston pumps

NOV Piston pumps

NOV is the world's largest manufacturer of API 674 standard piston pumps in the world. Their portfolio includes the former National, Oilwell, Wheatley, Gaso, Bear and MSW brands.

Benefits:

- materials: ductile iron, carbon steel, stainless steel, duplex, superduplex, Ni+Al+bronze
- cast and forged blanks
- 1-5 pistons
- double acting version available
- API 674 and ATEX certified
- wide range of sizes and designs



Maximum parameters

Flow rate:	254	m ³ /h
Pressure:	1379	bar



Drum pumps

Finish Thompson drum pumps and mixers

Finish Thompson offers a comprehensive range of drum pumps and mixers for pumping liquids with viscosities up to 100.000 cP. Thanks to the wide range of construction materials, maximum chemical resistance is guaranteed and the different pump lengths offer an easy and efficient solution for different tank sizes.

Finish Thompson pump and mixers options:

- materials: SS316, PP, PVC, PVDF, PTFE
- dimensions: 38-41-61-69-102-122-137-152-183 cm
- mechanic seals or sealless construction
- electric (12VDC, 230VAC) motors including ATEX certified versions
- air motor with ATEX certification
- lightweight
- hygienic connection option
- various suction elements to improve suction of viscous liquids



FINISH THOMPSON DRUM PUMPS AND MIXERS

Accessories: flow meters with cumulative and expansion function, hoses, pistols, filters, wall brackets

HDVP series maximum parameters

Flow rate:	9	m ³ /h
Pressure:	2,4 (9,1*)	bar
Product temperature:	105	°C

- EF economic medium duty serie
- PF high performance version with double suction for high flow rates
- BT version with additional PTFE screw compressor
- HVDP progressive cavity version for pumping the most viscous liquids
- TM drum mixers



Gear pumps

VIKING internal and external gear pumps

Characteristics: self-priming, robust, reversible, pulseless, high viscosity, hot and abrasive product pumping, pump variants meeting API 676 standard, internal and external gear series

Other benefits:

- materials: cast iron, ductile iron, steel, SS316
- internal gear – maximum flow rate, minimum wear parts
- connection size: 1/4" to 10" in the standard version
- more than a century of brand tradition
- heated versions (electrically or by a heat transfer medium)

UNIVERSAL SEAL	heavy-duty pump with design modifications and choice of seals
MOTOR SPEED	medium duty pump designed for high speed
UMD	heavy-duty pump with magnetic coupling
SPUR GEAR	external gear pump for high pressures
LVP	heavy-duty pump for low viscous liquids
LPG	pump designed for liquid gas pumping
ASP	pump designed for asphalt pumping

VIKING Chocolate Pump

A special version of the pump designed for chocolate pumping.

Benefits:

- patented double o-ring seal with sealing lubricant
- leak-free pumping
- enlarged tolerances and drilled gearing to reduce frictional heat
- hardened materials for increased abrasion resistance
- jacketed chamber
- food-grade materials and FDA approved elastomers seals
- product viscosity up to 200.000 cP

VIKING PUMP

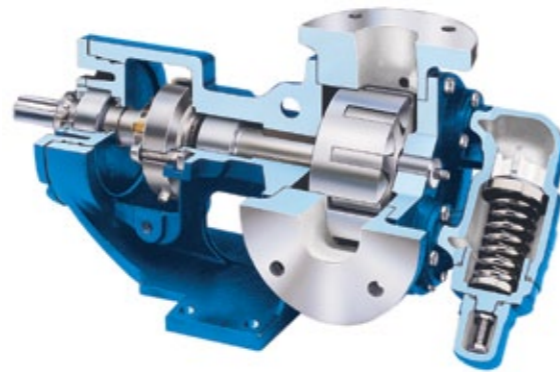

UNIVERSAL SEAL – HEAVY-DUTY SERIES

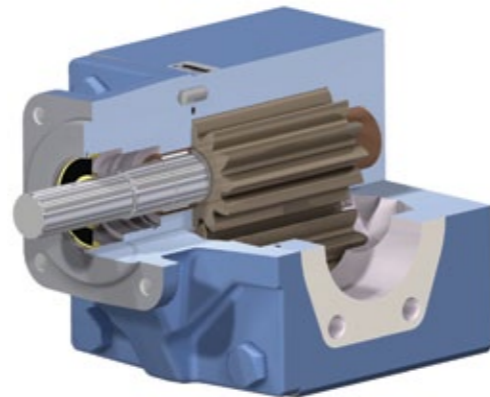

SPUR GEAR – EXTERNAL GEAR PUMP SERIES FOR HIGH PRESSURE

Maximum parameters		
Flow rate:	364	m ³ /h
Pressure:	170	bar
Product temperature:	371	°C

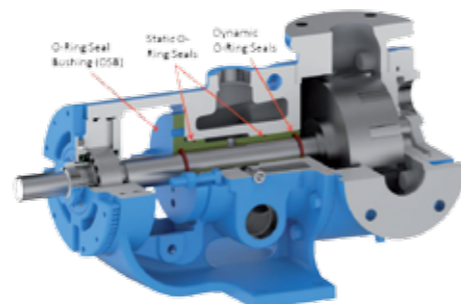

VIKING CHOCOLATE PUMP

Chocolate series maximum parameters		
Flow rate:	90	m ³ /h
Pressure:	14	bar
Temperature:	107	°C



Gear pumps

VIKING PUMP

VIKING internal gear pumps meeting API standard

The most advanced gear pumps for the most demanding applications in the petrochemical industry. VIKING offers 3 filling options following API 676 and API 682 standards.

UNIVERSAL SEAL	basic design with cartridge seal based on API 676 standard
UNIVERSAL 682	pump with cartridge seal according to API 682, with exceptions from the API 676 standard
XPD 676	pump fully meeting API 676 standard with cartridge seal according to API 682

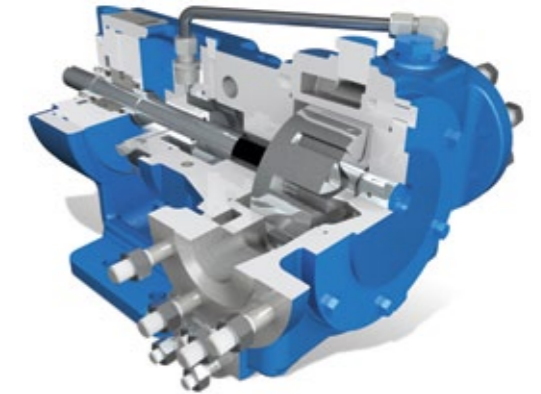

XPD 676 SERIES – FULLY COMPLIANT WITH THE API 676 STANDARD WITH CARTRIDGE SEAL ACCORDING TO API 682

Accessories: duplicated jacket, tempered parts, integrated safety valves, special mechanical and cartridge seals, strainer baskets

Series maximum parameters to API 676		
Flow rate:	250 (364*)	m ³ /h
Pressure:	14	bar
Product temperature:	205	°C

*UNIVERSAL 682 SERIES



UNIVERSAL 682 SERIES – WITH CARTRIDGE SEAL TO API 682

VIKING accessories

Strainer baskets

- easy cleaning thanks to easy opening of the insert lid
- basket design reduces pressure loss
- upper inlet eliminates the need to drain the line
- optional magnetic inserts for capturing ferromagnetic particles
- materials: cast iron or stainless steel
- dimensions from DN20 to DN150
- connection: flanges or NPT threads



VIKING STRAINER BASKETS



Gear pumps

All-plastic or metal gear pumps with magnetic coupling

Popular pumps in the chemical industry with great chemical resistance and sealless design.

Benefits:

- wetted stainless steel or all-plastic parts
- materials: PVDF, SS316
- covers: C, SiC
- elastomers: Viton, EPDM, Kalrez
- connection: 1/4" to 1 1/2"
- high chemical resistance
- sealless design
- dry running option
- popular solution for precise chemical dosing
- ATEX certified



ECLIPSE 5 METALLIC



ECLIPSE 25 NON-METALLIC

Maximum parameters		
Flow rate:	7,5	m ³ /h
Pressure:	10	bar
Product temperature:	65	°C

Precise microgear pumps with magnetic coupling

Extremely compact all-stainless steel pumps with magnetic coupling for precise dosing of small quantities.

Benefits:

- materials: SS316, Hastelloy-C276 and B2, Titan
- connection: 1/8" to 3/4"
- sealless design, pulseless run, high pressures
- suction shoe version – constant Q/H parameters over the entire service life
- OEM design, integrated 12 and 24VDC drives with adjustable speed control
- connection to IEC motor



MICROPUMP GJ SERIES



MICROPUMP GB SERIES

Maximum parameters		
Flow rate:	2,5	m ³ /h
Pressure:	8,7	bar
Product temperature:	177	°C



Gear pumps

High-pressure micro external gear pumps for precise pulseless dosing

Compact gear pumps with seals for adhesives, paints, refrigerants and food products dosing.

Benefits:

- materials: cast iron, hardened steel SS440B, SS316, ADLC coating, PEEK
- connection: 1/4" to 1"
- different types of seals
- suitable for pumping dyes, polyurethanes, silicone, adhesives, paints, etc.
- accuracy +/- 2 %
- repeatability +/- 0,5 %
- ATEX certified
- Swiss brand quality and tradition



POMTAVA 2610-1-1

Maximum parameters		
Flow rate:	20	l/min
Pressure:	100	bar
Product temperature:	135	°C

Pomtava 2008-3-1

Representative of special gear pumps with bypass block and pneumatic valve on the back of the pump to ensure the best possible flushing of gears.

Benefits:

- inlet flushing pressure max. 5 - 6 bar
- pneumatic valve with safety function option
- optional connection block for two pressure sensors with M28 or G¹/₂" threads
- mechanical seal with liquid barrier
- application: multi-component, UV paints



POMTAVA 2008-3-1

Maximum parameters		
Flow rate:	2	l/min
Pressure:	15	bar
Product temperature:	135	°C



Centrifugal pumps



MUNSCH ECM/CM

MUNSCH - Pumps from the German manufacturer MUNSCH represent the leading edge in the field of centrifugal pumps for chemical industry applications.

Characteristics: universal horizontal pumps with magnetic coupling, suitable for pumping clean corrosive products, wetted parts made of PFA or PP materials in a robust construction with pressure up to 16 bar.

Other benefits:

- chemical resistance thanks to PFA, PP and PVDF lining
- robust construction for pressures up to 16 bar
- abrasion resistance due to a wall thickness of over 10 mm
- sealless design with magnetic coupling
- monobloc versions available
- ATEX certification for all models

Maximum parameters		
Flow rate:	240	m ³ /h
Max. head:	90	m
Product temperature:	180	°C

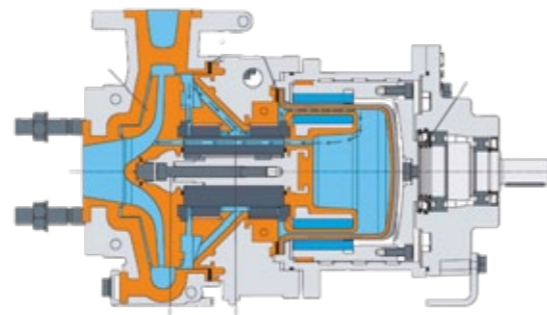

MUNSCH CM - MAGNETIC COUPLING



MUNSCH ECM - ECONOMICAL SERIES

MUNSCH CS

Characteristics: universal horizontal pumps with mechanical seal, suitable for pumping corrosive media with abrasive particles, single and double seal variations, available in different plastic lining materials for wide chemical compatibility

Other benefits:

- mechanical seal
- PFA, PP, PVDF plastic lining
- abrasion resistance due to a wall thickness of over 10 mm
- internal temperature sensor option
- monobloc versions available
- ATEX certification for all models

MUNSCH CS series maximum parameters		
Flow rate:	200	m ³ /h
Max. head:	90	m
Product temperature:	180	°C

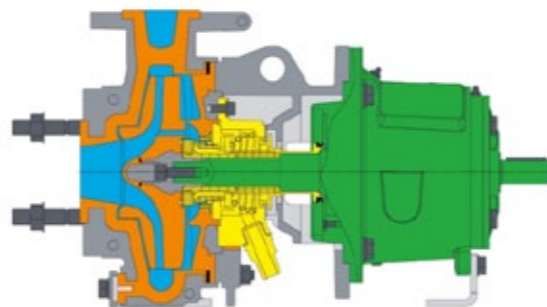

MUNSCH CS - SINGLE MECHANICAL SEAL



MUNSCH CS



Centrifugal pumps



MUNSCH NPC/NPC MAMMUT

Characteristics: king size pumps with single or double mechanical seals, flushing systems (non-pressurised and pressurised) and internal temperature sensor options.

Other benefits:

- exceptional flow rate - up to 5.000 m³/h
- pressure-resistant design up to 16 bar
- abrasion-resistant thanks to a wall thickness of over 10 mm
- chemical resistance thanks to PP, PVDF, PFA linings
- monobloc design option
- ATEX certification for all models

Maximum parameters		
Flow rate:	5.000	m ³ /h
Max. head:	100	m
Product temperature:	150	°C



MUNSCH NPC MAMMUT

MUNSCH TPC-M/TNP-KL

The MUNSCH range of compact submersible plastic pumps offers very good chemical resistance with the pumped medium and possibility of short-term dry running when the well is pumped out.

Characteristics: the most powerful range of submersible vertical pumps in monobloc design, with plastic construction in PP, PE-UHMW and PVDF materials and length up to 3,000 mm, fitted with labyrinth or mechanical seal.

Other benefits:

- robust construction up to 10 bar
- immersion length up to 3.000 mm
- labyrinth or mechanical seals
- range of accessories - strainer baskets and various shaped pipes
- ATEX certification for all models

Maximum parameters		
Flow rate:	700	m ³ /h
Max. head:	90	m
Product temperature:	120	°C

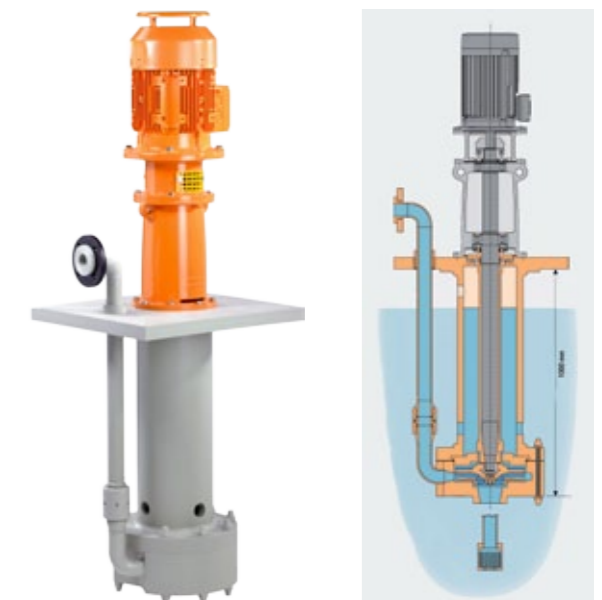

MUNSCH TPC-M



Centrifugal pumps

Pentax centrifugal pumps

Pentax is an Italian manufacturer of centrifugal pumps with economical and premium variants in horizontal and vertical designs, mainly for water and industrial applications.

CM EN 733

Economical cast iron monobloc centrifugal pumps meeting EN 733 standard for water applications.

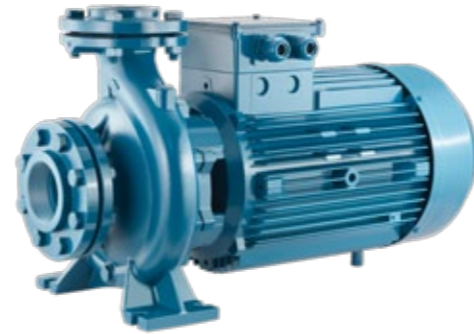

PENTAX CM EN 733

CM EN 733 series maximum parameters		
Flow rate:	330	m ³ /h
Max. head:	100	m
Product temperature:	90	°C

HP

Multi-stage booster pumps for water and other industrial applications. Wide selection of construction materials and seals, ATEX certified.

Other benefits:

- materials: cast iron, AISI 316, Duplex
- gland packing, single mechanical, balanced mechanical seal (C/SiC/EPDM)
- lubricated bearings
- EN or ANSI flanges
- water, agricultural, high pressure and other applications



PENTAX HP

HP series maximum parameters		
Flow rate:	1.200	m ³ /h
Max. head:	1.000	m
Product temperature:	180	°C

Vertical centrifugal pumps

Vertical multi-stage centrifugal pumps for pressurizing water and glycol.

Benefits:

- materials: stainless steel and cast iron
- ATEX certification
- AISI 304 pump cover
- mechanical seals (C/SiC/EPDM)
- compact footprint
- water treatment, pressure systems, irrigation, glycol water, heating and washing systems



PENTAX ULTRA L



PENTAX ULTRA V

Ultra V-L series maximum parameters		
Flow rate:	24	m ³ /h
Max. head:	140	m
Product temperature:	35	°C



Centrifugal pumps

ANDRITZ centrifugal pumps

Andritz is a manufacturer of centrifugal pumps for many industrial environments - mainly in the paper industry. Besides, they are used in the water, mining, energy, bioethanol and sugar industries.



ANDRITZ ACP & S

Horizontal centrifugal pumps

ACP & S series

Single-stage centrifugal pumps suitable for general applications but also for lightly contaminated products. These pumps stand out mainly because of their easy maintenance, low energy consumption and robust design.

Other benefits:

- stainless steel pump cover option
- wide range of applications - from the paper and energy industries up to the food industry
- high efficiency up to 90 %
- suitable for media with a solids content up to 8 %

Maximum parameters		
Flow rate:	9.000	m ³ /h
Max. head:	190	m
Product temperature:	200	°C

Split case pumps

Large energy pumps with split casing and easy service.

ASP series

The ASP series offers exceptional pumping efficiency, minimal pulsations and fast and easy maintenance thanks to the axial body design. ASP series can be installed horizontally or vertically (for horizontal installation, the motor can be placed on either left or right).



ANDRITZ ASP

Other benefits:

- energy savings
- low pulsations
- quick and easy maintenance
- applications: pumping of cooling water in power plants, paper industry
- single and multi-stage designs

Maximum parameters		
Flow rate:	40.000	m ³ /h
Max. head:	1.000	m
Product temperature:	80	°C



SPLIT CASE PUMPS



Centrifugal pumps

BUNGARTZ
CENTRIFUGAL PUMPS

Bungartz centrifugal pumps

Bungartz pumps are designed for extreme applications where other centrifugal pumps fail. They are the ideal solution for the demanding requirements of the chemical, petrochemical and energy industries.

Horizontal centrifugal pumps with hydrodynamic seal

Benefits:

- pumping corrosive, abrasive, crystalline and gel substances containing solids
- leak-free pumping thanks to the hydrodynamic seal
- no lubrication required
- reliable operation with low maintenance requirements
- ideal for use in fertiliser production (urea, acids, ammonium substances)
- additional expeller/impeller for better suction
- centrifugal regulator for vibration reduction
- easily replaceable wear parts
- jacketed pump body and hot steam flushing of internal parts options
- welded construction
- rubber coating

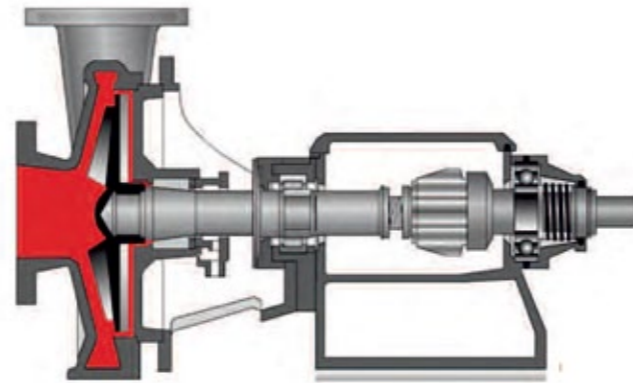

BUNGARTZ HORIZONTAL CENTRIFUGAL PUMPS WITH HYDRODYNAMIC SEAL

Maximum parameters		
Flow rate:	2.300	m ³ /h
Max. head:	130	m
Product temperature:	280	°C

MPCH DryRun

Centrifugal pump with magnetic coupling and a special nitrogen protective atmosphere technology ensures the correct function of the magnetic drive, long-term dry running function.

Areas of applications:

- toxic media
- liquids containing solids
- liquids containing gases



BUNGARTZ MPCH DRYRUN

Maximum parameters		
Flow rate:	550	m ³ /h
Max. head:	160	m
Product temperature:	400	°C



Centrifugal pumps

BUNGARTZ
CENTRIFUGAL PUMPS

Vertical centrifugal pumps

Unique pumps for use in ATEX zone 0.

Benefits:

- no danger of cavitation due to NPSHr ~ 0
- magnetic coupling or hydrodynamic seals variants
- applicable in ATEX zone 0
- dry running ability

Areas of applications:

- pumping chemicals at boiling point
- energy plants

Maximum parameters		
Flow rate:	1.200	m ³ /h
Max. head:	100	m
Product temperature:	300	°C



BUNGARTZ VERTICAL PUMPS

Bungartz pumping systems

Complete supply tanks draining without cavitation - ideal application for the self-regulating V-AN pump.

Areas of applications:

- separator extraction
- tanker pumping

Benefits:

- complete supply tanks draining with minimal residue
- suitable for liquids at boiling point
- hermetically sealed pump
- dry running option

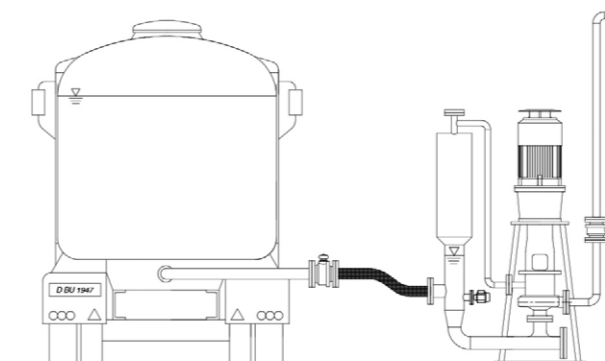

PUMPING SYSTEMS - NON-BOILING LIQUIDS

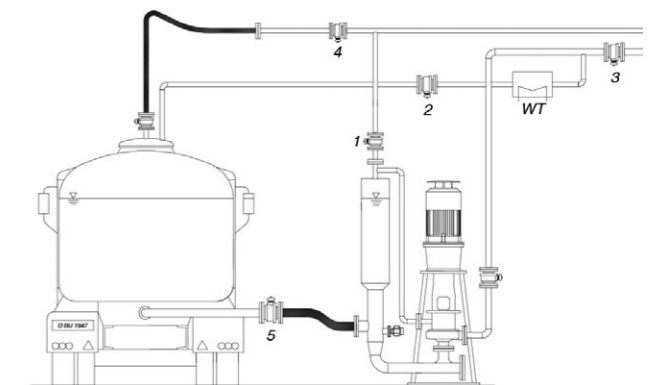

PUMPING SYSTEMS - BOILING LIQUIDS



Centrifugal pumps

Hermag canned motor pumps

Unique design of sealless centrifugal pumps with two containments for maximum operational safety when pumping toxic and radioactive products.

Other benefits:

- no risk of media leakage
- special medium-cooled motor
- plain bearings for long service life and minimal noise
- secondary containment in case of failure of the primary engine wall
- design meeting ISO 2858 or API 685 standard (fit or full compliance with the standard)
- ATEX zone 1 and 2
- range of special versions for heavy technical applications: hot media up to 450 °C, fast solidifying media, volatile media (LPG, LNG), self-priming, vertical, submersible

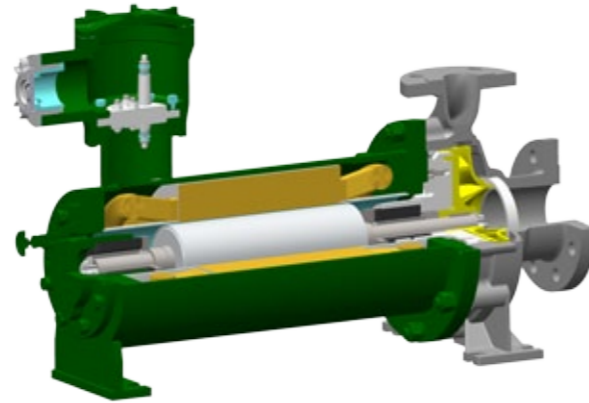

HERMAG CP - CONSTRUCTION CUT

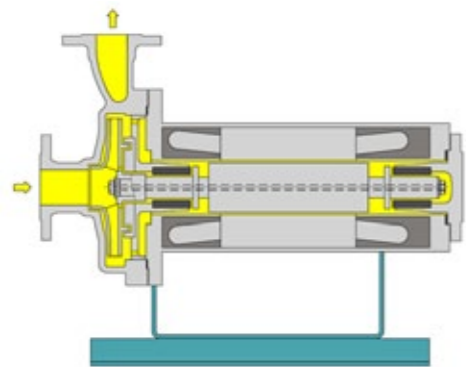

HERMAG CH - BASIC MODEL WITH INTERNAL CIRCULATION THROUGH HOLLOW SHAFT

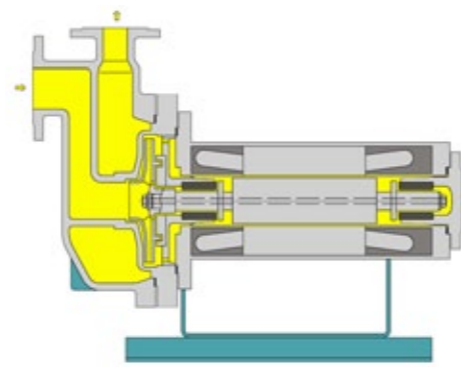

HERMAG CP - SELF-PRIMING VERSION FOR SUCTION LIFT UP TO 5M

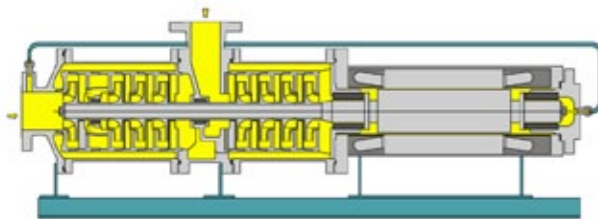

HERMAG CEM - MULTI-STAGE VERSION WITH HEAD UP TO 600M

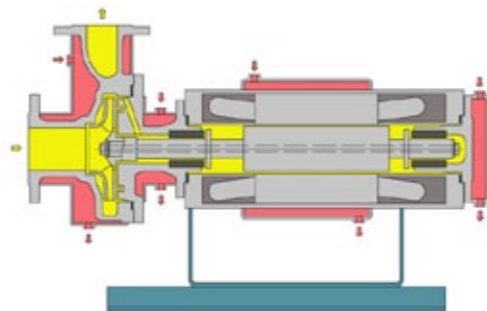

HERMAG CM - JACKETED VERSION FOR PRODUCTS WITH HIGH SOLIDIFICATION TEMPERATURE



Centrifugal pumps

Finish Thompson plastic centrifugal pumps

Characteristics: horizontal or vertical and self-priming construction with magnetic coupling and graphite bushings with dry running option

Other benefits:

- materials: PP, PVDF, ETFE, SS316, cast iron
- optimised design with magnetic coupling and high efficiency up to 70 %
- self-priming design
- modular design of vertical pumps with magnetic coupling with lengths up to 152 cm
- NPT, BSP, flange connection
- connection size DN 25 to DN 80



FINISH THOMPSON DB



FINISH THOMPSON - CENTRIFUGAL PUMPS

DB plastic centrifugal pumps with magnetic coupling up to 50 m³/h
 SP self-priming plastic centrifugal pumps with magnetic coupling up to 50 m³/h
 UC heavy-duty centrifugal pumps with magnetic coupling up to 329 m³/h , ETFE-lined ductile iron, Viton, EPDM, Simriz, Kalrez, Aflas seals options
 Other pump series - plastic, cast iron, stainless steel, with mechanical seal/magnetic coupling, self-priming, horizontal/vertical.

Maximum parameters		
Flow rate:	329	m ³ /h
Pressure:	20	bar
Product temperature:	121	°C



FINISH THOMPSON SP



Centrifugal pumps

Pompetravaini centrifugal pumps

Characteristics: horizontal monobloc or free shaft, closed or open impellers, self-priming, single or multi-stage, various seals options or versions with magnetic coupling.

Other benefits:

- materials: ductile iron, grey cast iron, SS316 stainless steel, Hastelloy-C, bronze and other special alloys
- standard design according to ISO 2858, 3069, 9906, 10816-3, 1940
- optional ISO 5199 for demanding chemical plants
- closed, semi-open, open, vortex impellers
- seals according to API requirements, choice of soft, mechanical, cartridge seals and magnetic couplings
- separate bearing housing for long service life
- TBH/GP series for LPG pumping



TCD - DESIGN FOR HEAT EXCHANGE OILS UP TO 320 °C WITH SIMPLE MECHANICAL SEALS WITHOUT THE NEED FOR COOLING DERIVED FROM DIN 24258 CHEMICAL PUMP STANDARD; BEARINGS ARE LUBRICATED WITH BEARING OIL AND NOT WITH PUMPED LIQUID AS IN COMPETITOR PRODUCTS.



TBA - SELF-PRIMING HIGH-PRESSURE PUMP DESIGN WITH VERY LOW NPSHR CAPABLE OF PUMPING LIQUIDS AT THE BOILING POINT WHILE MINIMIZING THE RISK OF CAVITATION; COMPACT BEARING SHIELD, SHORT SHAFT AND COMPACT DIMENSIONS ELIMINATE VIBRATIONS, WHICH EXTENDS BEARING AND SEAL LIFE.

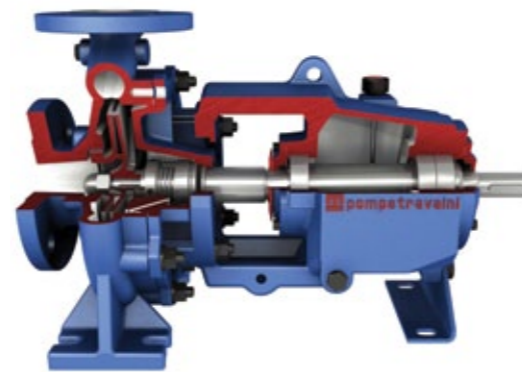

TCH - CLOSED IMPELLER DESIGN FOR CLEAN AND SLIGHTLY TURBID LIQUIDS

TCH	centrifugal pumps with closed impeller to 2.200 m ³ /h and 16 bar
TCHV	vertical pumps based on the TCH series
TCT	centrifugal pumps with opened/vortex impeller to 250 m ³ /h and 7 bar
TCHM-TCTM	monobloc pumps with closed/vortex impeller to 500 m ³ /h and 10 bar
TCA	single-stage pumps with fully opened impeller to 100 m ³ /h and 10 bar
TCD	single-stage pumps for transfer of heat exchange oils to 250 m ³ /h and 10 bar
TCK	single-stage pumps with magnetic coupling to 300 m ³ /h and 16 bar
TBA	self-priming multi-stage pumps with extra low NPSHr to 35 m ³ /h and 35 bar
TBH	self-priming multi-stage pumps with low NPSHr to 70 m ³ /h and 40 bar; GP version for pumping LPG
TMA-TMH	multi-stage pumps to 45 m ³ /h and 40 bar, resp. to 350 m ³ /h and 64 bar

Maximum parameters			
Flow rate:	2.200	m ³ /h	
Max. head:	16	bar	
Product temperature:	320	°C	



Vacuum pumps

Liquid-ring and dry running vacuum pumps, liquid-ring compressors

Characteristics: single-stage and double-stage liquid-ring vacuum pumps for a constant supply of vacuum to production technologies.

TRMX	budget, monobloc version, economical operation with up to 20 % more performance than the previous series, low sealing fluid consumption, anti-cavitation system, flow rate up to 65 m ³ /h
TRVX	single-stage vacuum pumps, central body impeller housing with integrated suction and discharge ports with optimised water supply; 50% reduction in water consumption, 30% material savings, 10% increase in capacity while maintaining drive performance compared to competing products, up to 1.050 m ³ /h
TRVN	single-stage vacuum pumps for demanding applications to 600 m ³ /h
TRM-TRV	single-stage vacuum pumps to 270 m ³ /h, resp. 500 m ³ /h and 33 mbar(a)
TRH-TRS	single/double-stage vacuum pumps to 3.500 m ³ /h
TRVK	single-stage vacuum pumps for high level of vacuum, to 23.000 m ³ /h
TRSK	single-stage vacuum pumps for medium and high vacuums, up to 30.000 m ³ /h
BORA	dry running, rotary pistons vacuum pumps to 3.000 m ³ /h - unlike liquid ring vacuum pumps, there is no need for service liquid
SA	liquid ring compressors for pressures to 11 bar; up to 110 m ³ /h



TRH SERIES



BORA DRY RUNNING VACUUM PUMPS

Other benefits:

- materials: SS316, grey cast iron
- free shaft and monobloc versions
- large flow range and high vacuum capabilities
- many years of manufacturer experience and active development of new series

Maximum parameters			
Flow rate:	30.000	m ³ /h	
Vacuum:	33	mbar abs.	

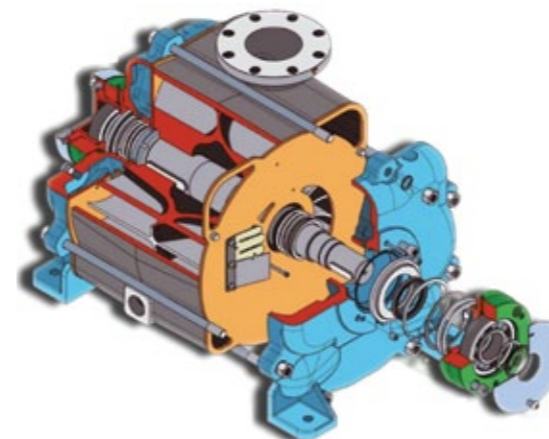

TRVX SERIES



TRVN SERIES



AxFlow Service

- it's about keeping your processes running

Quality, fast and professionally done installation of the equipment. Design, assembly, programming and commissioning of complete solutions and systems and their follow-up maintenance. Everything tailored to the customer is the basis for an efficient and reliable operation.

AxFlow provides services at its service centers or directly at the customer. We draw on 25 years of experience in sales and service of equipment in the industry and close cooperation with the production sites of the world's best manufacturers.

All AxFlow service technicians are regularly trained on our complete range of products during joint AxFlow Group seminars and directly at our suppliers' production sites.

Our customers have the advantage of both warranty and post-warranty scheduled services that minimize the risk of a sudden breakdown or accident in the technology. When such an event does occur, our emergency service is there to reduce the impact of unplanned downtime.

With our company's technical know-how, we provide these services not only for products distributed by us, but also for other types and brands of pumps, vacuum pumps and other equipment, including original spare parts.

WHAT WE OFFER



INSTALLATION



EMERGENCY SERVICE



MAINTENANCE



LOGISTICS



CONTRACTS



QUALITY AND WARRANTY

EUROPEAN DISTRIBUTION CENTRE - FAST DELIVERY OF STOCK SPARE PARTS AND PUMPS

fluidity.nonstop® is our promise and our goal. It expresses our commitment to providing a high level of service and offering quality products, technical solutions and expertise that are at the top of the industry.

We are Europe's leading supplier of pumping technology and technical consultancy with a focus on the process industry. As we aim to maintain this position, we work tirelessly to offer you the best solutions.



AxFlow s.r.o., K Hrušovu 292/4, CZ-102 00 Praha 10

axflow@axflow.cz
www.axflow.cz

AxFlow s.r.o., o.z.p.z.o., Zábranie 56, SK-920 01 Hlohovec

axflow@axflow.sk
www.axflow.sk

